

402VLZ4

4-Channel Ultra-Compact Mixer

OWNER'S MANUAL



Important Safety Instructions

1. Read these instructions.
2. Keep these instructions.
3. Heed all warnings.
4. Follow all instructions.
5. Do not use this apparatus near water.
6. Clean only with a dry cloth.
7. Do not block any ventilation openings. Install in accordance with the manufacturer's instructions.
8. Do not install near any heat sources such as radiators, heat registers, stoves, or other apparatus (including amplifiers) that produce heat.
9. Do not defeat the safety purpose of the polarized or grounding-type plug. A polarized plug has two blades with one wider than the other. A grounding-type plug has two blades and a third grounding prong. The wide blade or the third prong are provided for your safety. If the provided plug does not fit into your outlet, consult an electrician for replacement of the obsolete outlet.
10. Protect the power cord from being walked on or pinched particularly at plugs, convenience receptacles, and the point where they exit from the apparatus.
11. Only use attachments/accessories specified by the manufacturer.
12. Use only with a cart, stand, tripod, bracket, or table specified by the manufacturer, or sold with the apparatus. When a cart is used, use caution when moving the cart/apparatus combination to avoid injury from tip-over.



13. Unplug this apparatus during lightning storms or when unused for long periods of time.
14. Refer all servicing to qualified service personnel. Servicing is required when the apparatus has been damaged in any way, such as power-supply cord or plug is damaged, liquid has been spilled or objects have fallen into the apparatus, the apparatus has been exposed to rain or moisture, does not operate normally, or has been dropped.
15. This apparatus shall not be exposed to dripping or splashing, and no object filled with liquids, such as vases or beer glasses, shall be placed on the apparatus.
16. Do not overload wall outlets and extension cords as this can result in a risk of fire or electric shock.
17. The MAINS plug or an appliance coupler is used as the disconnect device, so the disconnect device shall remain readily operable.

18. **NOTE:** This equipment has been tested and found to comply with the limits for a Class B digital device, pursuant to part 15 of the FCC Rules. These limits are designed to provide reasonable protection against harmful interference in a residential installation. This equipment generates, uses, and can radiate radio frequency energy and, if not installed and used in accordance with the instructions, may cause harmful interference to radio communications. However, there is no guarantee that interference will not occur in a particular installation. If this equipment does cause harmful interference to radio or television reception, which can be determined by turning the equipment off and on, the user is encouraged to try to correct the interference by one or more of the following measures:

- Reorient or relocate the receiving antenna.
- Increase the separation between the equipment and the receiver.
- Connect the equipment into an outlet on a circuit different from that to which the receiver is connected.
- Consult the dealer or an experienced radio/TV technician for help.

CAUTION: Changes or modifications to this device not expressly approved by LOUD Audio, LLC. could void the user's authority to operate the equipment under FCC rules.

19. This apparatus does not exceed the Class A/ Class B (whichever is applicable) limits for radio noise emissions from digital apparatus as set out in the radio interference regulations of the Canadian Department of Communications.

ATTENTION — Le présent appareil numérique n'émet pas de bruits radioélectriques dépassant les limites applicables aux appareils numériques de class A/de class B (selon le cas) prescrites dans le règlement sur le brouillage radioélectrique édicté par les ministères des communications du Canada.



The lightning flash with arrowhead symbol within an equilateral triangle is intended to alert the user to the presence of "uninsulated" ("dangerous voltage" within the product's enclosure, that may be of sufficient magnitude to constitute a risk of electric shock to persons.
Le symbole éclair avec point de flèche à l'intérieur d'un triangle équilatéral est utilisé pour alerter l'utilisateur de la présence à l'intérieur du coffret de "voltage dangereux" non isolé d'ampères suffisante pour constituer un risque d'électrocution.



The exclamation point within an equilateral triangle is intended to alert the user of the presence of important operating and maintenance (servicing) instructions in the literature accompanying the appliance.
Le point d'exclamation à l'intérieur d'un triangle équilatéral est employé pour alerter les utilisateurs de la présence d'instructions importantes pour le fonctionnement et l'entretien (service) dans le livret d'instruction accompagnant l'appareil.

20. Exposure to extremely high noise levels may cause permanent hearing loss. Individuals vary considerably in susceptibility to noise-induced hearing loss, but nearly everyone will lose some hearing if exposed to sufficiently intense noise for a period of time. The U.S. Government's Occupational Safety and Health Administration (OSHA) has specified the permissible noise level exposures shown in the following chart.

According to OSHA, any exposure in excess of these permissible limits could result in some hearing loss. To ensure against potentially dangerous exposure to high sound pressure levels, it is recommended that all persons exposed to equipment capable of producing high sound pressure levels use hearing protectors while the equipment is in operation. Ear plugs or protectors in the ear canals or over the ears must be worn when operating the equipment in order to prevent permanent hearing loss if exposure is in excess of the limits set forth here:

Duration Per Day in hours	Sound Level dBA, Slow Response	Typical Example
8	90	Duo in small club
6	92	
4	95	Subway Train
3	97	
2	100	Very loud classical music
1.5	102	
1	105	Matt screaming at Troy about deadlines
0.5	110	
0.25 or less	115	Loudest parts at a rock concert

WARNING — To reduce the risk of fire or electric shock, do not expose this apparatus to rain or moisture.

Please write your serial number here for future reference (i.e., insurance claims, tech support, return authorization, make dad proud, etc.)

Purchased at:

Date of purchase:

Contents

Important Safety Instructions.....	2
Features.....	4
Introduction.....	4
How To Use This Manual.....	4
Getting Started	5
Things to Remember.....	5
Hookup Diagrams	6
Front & Rear Panel Features.....	12
1. Power Switch	13
2. Power Connection.....	13
3. Mic Ins (Ch.1-2)	13
4. Line Ins (Ch.1-2)	13
5. Low Cut (Ch.1-2)	13
6. Instrument Switch (Ch.1-2)	14
7. Gain (Ch.1-2)	14
8. Hi EQ.....	14
9. Low EQ.....	15
10. Stereo Pan Switch (Ch.1-2)	15
11. Level	15
12. OL LED	15
13. Main Outs.....	15
14. Stereo Line Ins (Ch.3-4)	16
15. Tape Assign To Main.....	16
16. Tape Level	16
17. Tape In	16
18. Tape Out.....	16
19. Phones.....	16
20. Phantom Power Switch	17
21. Phones Level.....	17
22. Main Mix	17
23. Power LED	17
24. Meters	17
Appendix A: Service Information.....	18
Appendix B: Connections.....	19
Appendix C: Technical Information	20
Block Diagram	21
Dimensions / Microphone Stand.....	22
402VLZ4 Limited Warranty.....	23



Like us



Follow us



Watch our dang videos

Features

- 4-channel mixer featuring our signature high-headroom, low-noise design
- 2 boutique-quality Onyx mic preamps
 - Ultra-wide 60 dB gain range
 - 128.5 dB dynamic range
 - +22 dBu line input handling
 - Extended frequency response
 - Distortion under 0.0007% [20 Hz – 50 kHz]
- Improved RF rejection, perfect for broadcast applications
- Phantom power for condenser mics
- 4 high-headroom line inputs
- Selectable instrument inputs on first two channels – no DI box needed
- 2-band EQ (80 Hz, 12 kHz)
- 18 dB/oct 100 Hz low-cut filter on mic input channels
- High-resolution 8-segment stereo meters
- Sealed rotary controls resist dust and grime
- “Built-Like-A-Tank” rugged steel chassis with powder-coat finish
- High-visibility, high-contrast controls deliver convenient “at-a-glance” visual feedback

Introduction

The 4-channel 402VLZ4 features our flagship Onyx mic preamps in an ultra-compact design that is an industry-leading performer ideal for professional low-input applications.

From every input to every output, the 402VLZ4 is designed to provide the highest headroom and lowest noise possible for maximum signal integrity.

Plus, it truly is “Built-Like-A-Tank” with a ridiculously rugged solid steel chassis and high-contrast controls for ultimate tactile control.

And with features like instrument level inputs, phantom power and level metering, the 402VLZ4 is the premier mixer choice for anybody who’s big on performance, but light on inputs.

How To Use This Manual

After this introduction, a getting started guide will help you get things set up fast. The hookup diagrams show some typical setups, while the remaining sections provide details of the 402VLZ4 mixer.



This icon marks information that is critically important or unique to the 402VLZ4. For your own good, read and remember them.



This icon will lead you to in-depth explanations of features and some practical tips. They usually have some valuable nuggets of information.



This icon draws attention to certain features and functions relating to the usage of the 402VLZ4.

Getting Started

The following steps will help you set up the 402VLZ4 mixer quickly.

1. Make all initial connections with the power switches OFF on all equipment. Make sure the gain knobs and main mix knob are fully down [counter-clockwise].
2. Set the level knobs and EQ knobs at the center [unity].
3. Connect the signal source to the input of channel 1.
4. Connect the main outputs of the 402VLZ4 to the inputs of powered speakers [or to the inputs of an amplifier which should be connected to passive speakers].
5. Push the 3-pin female side of the power adaptor securely into the connector on the rear of the 402VLZ4. Plug the other end into an AC outlet properly configured with the correct voltage as indicated on the AC adaptor.
6. Light some incense, man...
7. Turn the mixer on.
8. Turn the speakers on.
9. Start the signal source and raise the main mix knob up until audio may be heard through the speakers.
10. Adjust the gain control so that the OL LED does not come on very often, if at all, even during the loudest parts of your program.
11. If you'd like to apply some EQ, do so now and repeat step 9.
12. Repeat for channel 2, if required.

Things to Remember

- Never listen to loud music for prolonged periods. Please see the Safety Instructions on page 3 for information on hearing protection.
- As a general guide, the 402VLZ4 should be turned on first, then the speakers. As such, the mixer should also be turned off last. This will reduce the possibility of any turn-on or turn-off thumps and other noises generated by any upstream equipment from coming out of the speakers.
- Save the shipping boxes and packing materials! You may need them someday. Besides, the cats will love playing in them and jumping out at you unexpectedly. Remember to pretend that you are surprised!
- Save your sales receipt in a safe place.

Hookup Diagrams

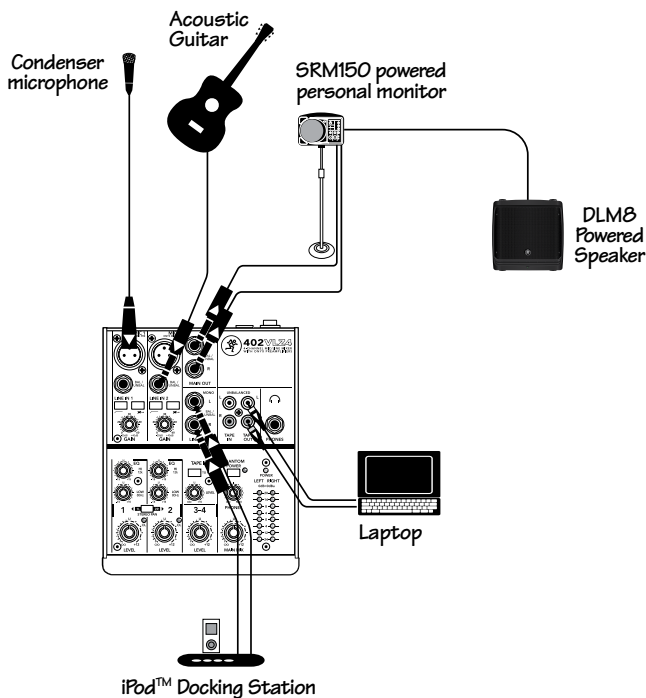

This diagram shows a microphone connected to channel 1's mic input, with the phantom power switch pressed in. A guitar is attached to the instrument input of channel 2, with the instrument switch pressed in.

An iPod™ docking station is connected to the line-level inputs of channels 3 and 4, so you can play to a pre-recorded backing track, or play music during the breaks caused by drinking too many free lattes. You may need two 1/4" to RCA adapters to make these connections.

The tape outputs are connected to the line-level stereo inputs of a laptop's sound card. This allows you to record the entire performance using the DAW of your choice.

The mic and guitar are panned mono, so the same mix is coming out of the main left and right outputs, and each may be used for a monitor or a front-of-house loudspeaker as follows:

The left and right main mix outputs connect to an SRM150 powered personal monitor. This is pointed at the performer (the fabulous you). The thru output of the SRM150 feeds the input of a DLM8 powered loudspeaker playing to your appreciative, jittery, hopped-up-on-the-bean audience. Jump quickly from one song to another, and keep the poetry about the Washington State Rain Festival (Jan 1st-Dec 31st) to a minimum.

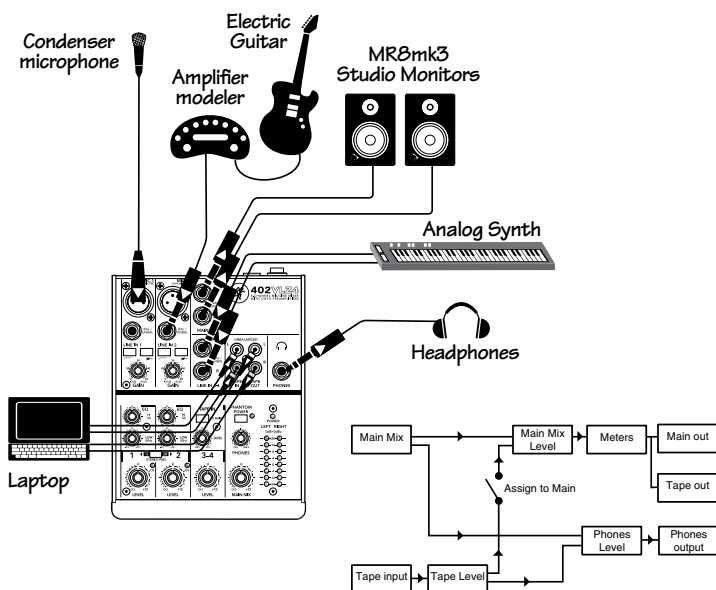

This diagram shows a condenser microphone connected to channel 1's mic input, with the phantom power switch pressed in.

The line-level output from a popular guitar amplifier modeler feeds the line input of channel 2.

A stereo synth connects to the line inputs of channels 3 and 4.

A laptop computer running the DAW of your choice is connected to the tape input and output.

A pair of headphones allows you to hear the main mix as you play.

A pair of studio reference monitors is connected to the main mix outputs.

For a recording session example, you can record the vocals, guitar and keyboards.

These can be recorded as individual tracks, and you can listen directly through the headphones. If you are recording through the mic, listen through the headphones only, and turn off power to your loudspeakers. (The main mix level still needs to be up, so you can record the tape out.)

For overdubbing, you will be playing live, and recording a new track onto the computer through the tape outputs. You can listen to the pre-recorded tracks and your live playing at the same time in the headphones. Adjust the tape level to find a nice mix of the playback compared to your playing. If the "assign to main" is out, then the pre-recorded tracks will not appear in the tape out or main mix, so only your new playing is recorded.

To playback the recording, adjust the tape level control to hear it in the headphones. Press "assign to main" in, and slowly bring up the main mix level to hear the results of all your efforts in the studio monitors.

Recording with a Computer

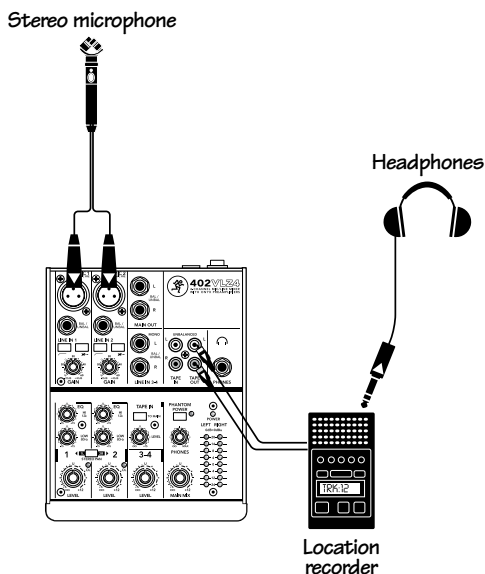
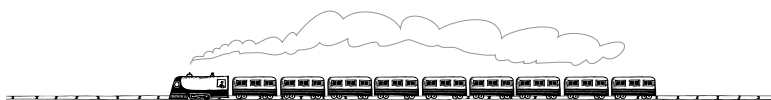

This diagram shows the outputs of a stereo microphone connected to the mic inputs of channels 1 and 2. The stereo pan switch is pressed in, so channel 1 goes only to the left of the main mix, and channel 2 goes to the right.

The tape output is connected to a location recording device, with a set of headphones attached. It is best to keep the headphones on the last device in your recording chain (the recording device). Many flash-based digital devices are available.

Set the main mix output level control to unity (U) and use the recorder's own level control to adjust the levels going to the recorder. Each channel from the microphone may be adjusted with the channel level controls. Keep them at the same level to retain the true balance from the microphone.

Location Sound

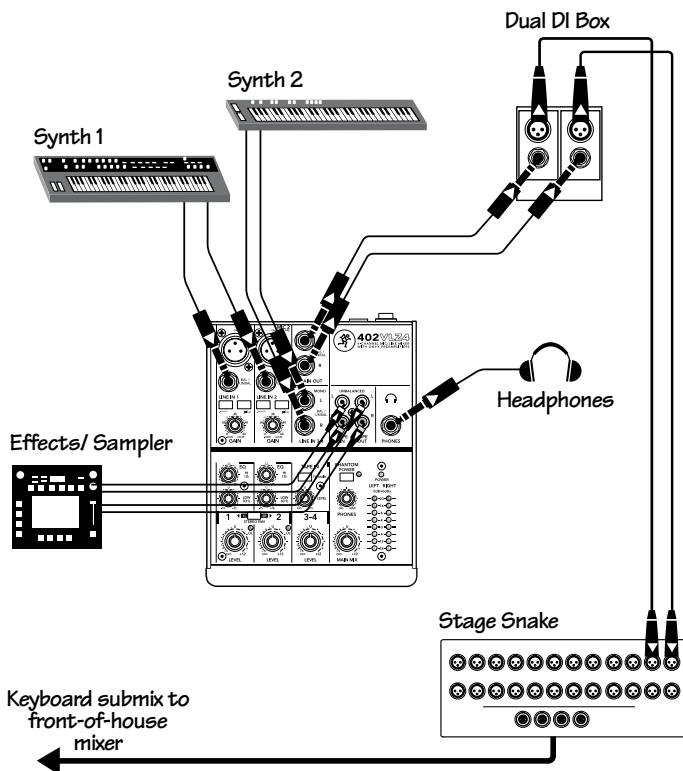

This diagram shows the stereo outputs of a synth connected to the line inputs of channels 1 and 2. The stereo pan switch is pressed in, so channel 1 only goes to the left of the main mix, and channel 2 only goes to the right.

Another stereo synth is connected to the line-level inputs of channels 3 and 4.

An effects/sampler is connected to the tape input and tape output. The "assign to main" switch is pressed in during playback, so the output from the effects/sampler will appear in the main mix. Leave the switch out when capturing sounds.

The line-level main mix output connects to the inputs of a dual DI box. This converts the output so it is suitable for connecting to the inputs of a stage snake connected to the inputs of the front of house mixer.

A pair of headphones allows you to hear the main mix as you play. Between songs, you can turn down the main output to the FOH mixer, and experiment with sounds and new patches and still listen in the headphones without upsetting the audience.

Keyboard Submixer

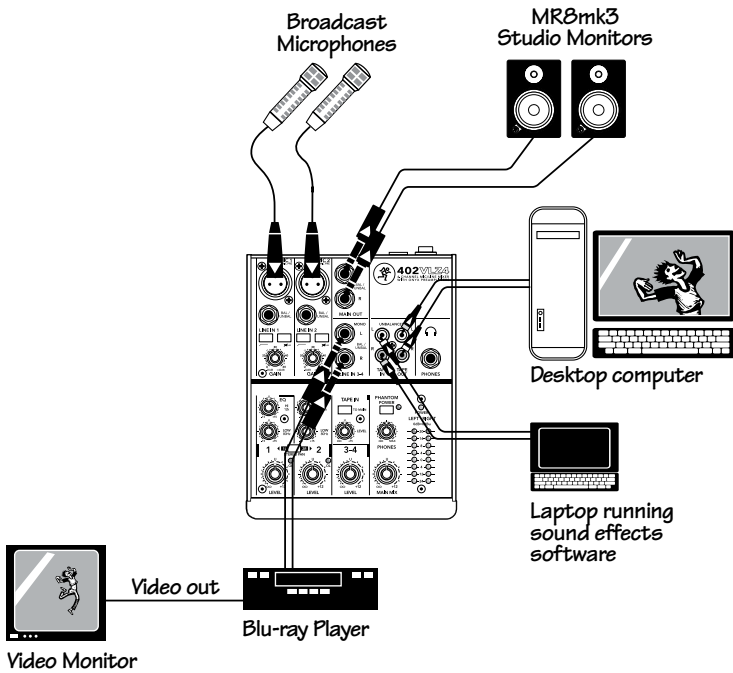

This diagram shows two voice-over microphones connected to the mic inputs of channels 1 and 2.

The stereo line-level output from a Blu-ray player connects to the line inputs of channels 3 and 4.

A laptop running sound effect software is connected to the tape input. The "assign to main" switch is pressed in, so the sound effects can be added to the main mix.

The tape output connects to the line-level audio input of a desktop computer running your favorite DAW.

The main outputs feed a pair of powered studio reference monitors.

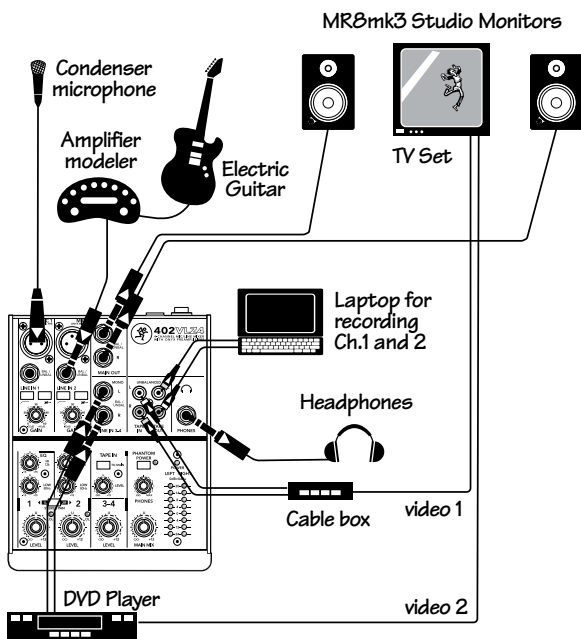

This diagram shows how you can use the mixer to control a home studio and a home theater, using the same set of loudspeakers. This is useful if you are short on space, or you are in love with a really nice pair of loudspeakers and want to share them between your home theater and home studio.

A condenser microphone is connected to channel 1's mic input, with phantom power engaged. The line-level output from a guitar amplifier modeler feeds the line input of channel 2.

A laptop computer running the DAW of your choice is connected to the tape output, so you can record channels 1 and 2.

The stereo line-level audio output from a cable box is connected to the tape inputs, and the video output from the cable box connects to the TV monitor. If you press "assign to main," the audio will be added to the main mix.

The stereo line-level audio output from a DVD player is connected to the line inputs of channels 3 and 4, and the video output connects to the TV monitor. A pair of headphones allows you to hear the main mix.

To use the home studio, sing and play your guitar, and record using the DAW, or listen through the nice speakers. Turn down channels 3 and 4, and do not assign the tape inputs to the main mix from the cable box.

To use the home theater, turn down channels 1 and 2. Select a program using the cable box, and assign the tape inputs to the main mix. Listen to the audio in your nice speakers. If you play a DVD, adjust channels 3 and 4, and turn off the "assign to main" switch. Select the DVD video with your TV set.

Combined Home Studio/Home Theater

Front & Rear Panel Features

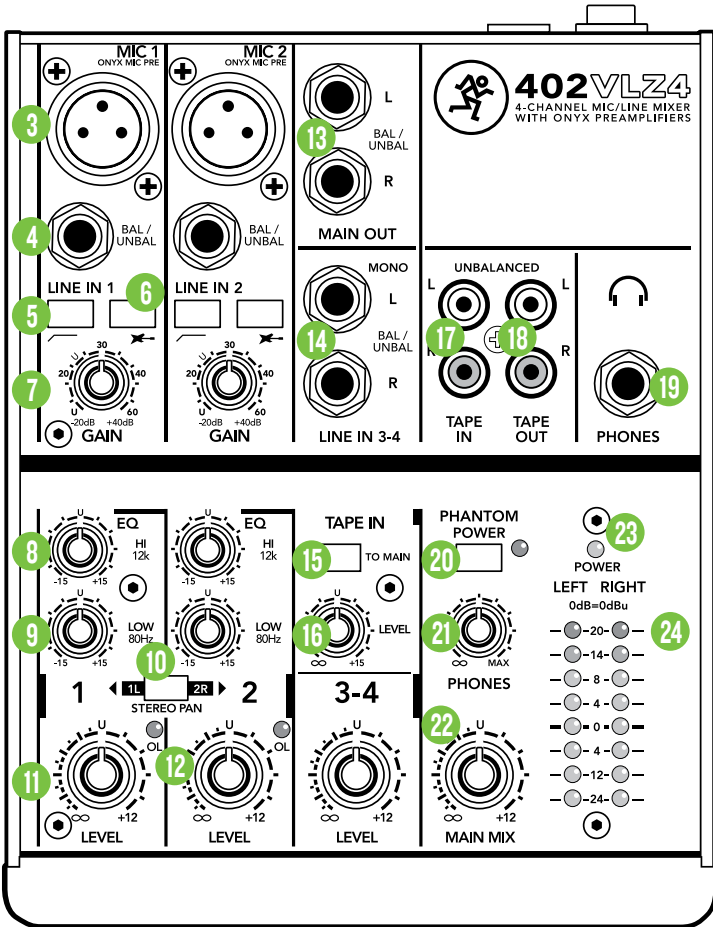
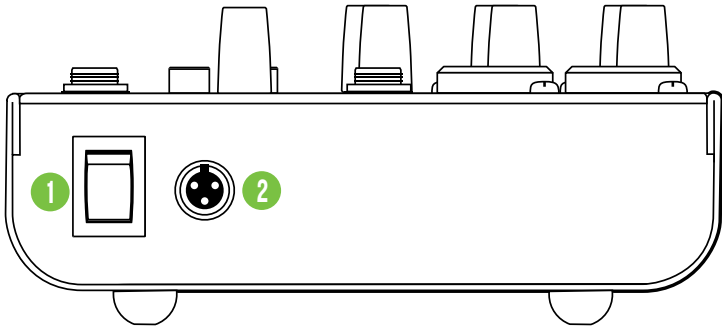

I. Power Switch

Press the top of this rocker switch inwards to turn on the mixer. The power LED [23] on the top surface of the mixer will glow with happiness. Press the bottom of this switch to put the mixer into standby mode. It will not function, but the circuits are still live. To remove power, either turn off the mains supply, or unplug the power cord from the mixer and the mains supply.

As a general guide, turn on your mixer first, before the power amplifier or powered speakers, and turn it off last. This will reduce the possibilities of any turn-on, or turn-off thumps in your speakers.

2. Power Connection

Push the 3-pin female side of the power adaptor securely into the connector on the rear of the mixer. Plug the other end into an AC outlet properly configured with the correct voltage as indicated on the AC adaptor.

Only use the AC adapter that came with your mixer, or a factory-authorized power supply.

3. Mic Ins (Ch. 1-2)

Phantom-powered, balanced Onyx mic preamps are on every VLZ4 mixer. These circuits are excellent at rejecting hum and noise. You can plug in almost any kind of mic that has a standard XLR male mic connector.

Professional ribbon, dynamic, and condenser mics will all sound excellent through these inputs. The 402VLZ4's mic inputs will handle any kind of mic level you can toss at them, without overloading.

Phantom Power

Most modern professional condenser mics are equipped for phantom power, which lets the mixer send low-current DC voltage to the mic's electronics through the same wires that carry audio. (Semi-pro condenser mics often have batteries to accomplish the same thing.) "Phantom" owes its name to an ability to be "unseen" by dynamic mics (Shure SM57/SM58, for instance), which don't need external power and aren't affected by it anyway.

The phantom power for both channels 1 and 2 is turned on and off together using the phantom power [20] switch.



Never plug single-ended (unbalanced) microphones or instruments into the mic input jacks if the phantom power is on.



Do not plug instrument outputs into the mic input jacks with phantom power on, unless you know for certain it is safe to do so.



Do not use phantom power with ribbon microphones.

4. Line Ins (Ch. 1-2)

These inputs share circuitry (but not phantom power) with the mic preamps, and can be driven by balanced or unbalanced sources at almost any level. You can use these inputs for virtually any audio signal you'll come across.

To connect balanced lines to these inputs, use a 1/4" Tip-Ring-Sleeve (TRS) plug.

To connect unbalanced lines to these inputs, use a 1/4" mono (TS) phone plug or standard instrument cable.

These two line inputs are a good place to connect older instruments that need more gain. You can correct weak levels by adjusting the channel's gain control [7].

5. Low Cut (Ch. 1-2)

Each low-cut switch, often referred to as a high-pass filter (all depends on how you look at it), cuts bass frequencies below 100 Hz at a rate of 18 dB per octave.

We recommend that you use low-cut on every microphone application except kick drum, bass guitar, or bassy synth patches. These aside, there isn't much down there that you want to hear, and filtering it out makes the low stuff you do want much more crisp and tasty. Not only that, but low-cut can help reduce the possibility of feedback in live situations, and it helps to conserve amplifier power.



Another way to consider low-cut's function is that it actually adds flexibility during live performances.

With the addition of low-cut, you can safely use low equalization on vocals. Many times, bass shelving EQ can really benefit voices. Trouble is, adding low EQ also boosts stage rumble, mic handling clunks and breath pops. Applying low-cut removes all those problems, so you can add low EQ without blowing a subwoofer.

6. Instrument Switch (Ch. 1-2)

When this switch is pressed in, channel 1 or 2's line input can accept direct instrument-level signals from guitars or other instruments. They will be impedance-matched to the line input, without the need for a DI box.

When this switch is out, you can connect line-level sources such as CD players, MP3 players, keyboards, drum machines and more. You will need a DI box if connecting instrument-level signals to the inputs of channel 3 and 4.



Direct-In (DI) boxes are commonly available from most music stores.

They provide signal and impedance matching for the direct connection of guitars and other instruments to amplifiers and mixers. They convert unbalanced instrument-level signals to a balanced mic-level output. Normally, they just look like a funny little box with a 1/4" TS input at one end, and an XLR output at the other. The good thing is that you do not need them with the 402VLZ4.

7. Gain (Ch. 1-2)



If you haven't already, please read the 'Getting Started' section on page 5.

Gain adjusts the input sensitivity of the mic and line inputs connected to channels 1 and 2. This allows signals from the outside world to be adjusted to optimal internal operating levels.

If the signal comes through the XLR jack, there will be 0 dB of gain with the knob fully down, ramping to 60 dB of gain fully up.

Through the 1/4" input, there is 20 dB of attenuation fully down and 40 dB of gain fully up, with a "U" (unity gain) mark at 10:00. This 20 dB of attenuation can be very handy when inserting a very hot signal, or when you want to add a lot of EQ gain, or both. Without this "virtual pad," this scenario might lead to channel clipping.

"U" Like Unity Gain

VLZ4 mixers have a "U" symbol on almost every level control. This "U" stands for "unity gain," meaning no change in signal level. Once you have adjusted the input signal to line-level, you can set every control at "U" and your signals will travel through the mixer at optimal levels. What's more, all the labels on our level controls are measured in decibels (dB), so you'll know what you're doing level-wise if you choose to change a control's settings.

2-Band Equalization

The 402VLZ4 has 2-band equalization at carefully selected points — low shelving at 80 Hz, and hi shelving at 12 kHz. "Shelving" means that the circuitry boosts or cuts all frequencies past the specified frequency. For example, rotating the low EQ knob 15 dB to the right boosts bass starting at 80 Hz and continuing down to the lowest note you never heard.



With EQ, you can also screw things up royally. We've designed a lot of boost and cut into each equalizer circuit, because we know everyone will occasionally need that. But if you max the EQs on every channel, you'll get mix mush. Equalize subtly and use the left sides of the knobs (cut), as well as the right (boost). Very few gold-record-album engineers ever use more than about 3 dB of EQ. If you need more than that, there's usually a better way to get it, such as placing a mic differently (or using a different kind of mic entirely).

8. Hi EQ

This control gives you up to 15 dB boost or cut above 12 kHz, and it is also flat at the center.

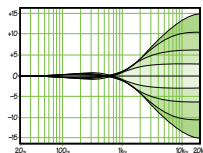

Use it to add sizzle to cymbals, and an overall sense of transparency, or edge to keyboards, vocals, guitar and bacon frying. Turn it down a little to reduce sibilance, or to hide tape hiss.

9. Low EQ

This control gives you up to 15 dB boost or cut below 80 Hz. The circuit is flat (no boost or cut) at the center position. This frequency range represents the punch in bass drums, bass guitar, fat synth patches, and some really serious male singers.

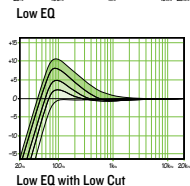
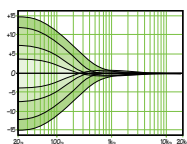

Used in conjunction with the low cut [5] switch, you can boost the low EQ without injecting a ton of subsonic debris into the mix.

10. Stereo Pan Switch (Ch. 1-2)

With this switch out, each mono channel feeds both the left and right sides of the main mix equally. For example:

- **Playing a mono source:** If you talk into a microphone connected to input 1, your sweet tones will be heard in both the left and right loudspeakers.
- **Overdubbing a mono source:** if you are monitoring directly through the headphones, you can hear the overdub signal in both ears while you are playing.

With this switch pressed in, channel 1 will play only in the left side of the main mix, and channel 2 will play in the right side. For example:

- **Recording a stereo source:** If you have a stereo microphone connected to the mic inputs, or if you are playing a stereo source into the line inputs, each side of the source can be recorded discretely onto a recorder connected to the main or tape outputs.

The pan switch does not affect channels 3 or 4, or the tape inputs.

11. Level

This adjusts the channel's level from off, to unity gain at the center, on up to 12 dB of additional gain. Once the gain [7] has been adjusted for each channel, use the level to adjust how much of each channel appears in the main mix.

Channels 1 and 2 use mono level controls, and channels 3 and 4 uses a stereo control.

12. OL LED

This overload LED will illuminate if the input signal is too high. The signal level is measured just before the level control, but after the gain control and EQ.

If the OL LED does illuminate, turn down the gain and/or the EQ controls until this will only illuminate occasionally when the input source is running high. Turning the level control will not affect the OL LED.

13. Main Outs

These outputs feed the main mix out into the waiting world. They can be connected to the line-level inputs of power amplifiers, powered speakers, or to the line inputs of another mixer.

To use these outputs to drive balanced inputs, connect 1/4" TRS (Tip-Ring-Sleeve) phone plugs like this:

- Tip = + (hot)
- Ring = - (cold)
- Sleeve = Ground

For most music recording and PA applications, unbalanced lines are fine. To drive unbalanced inputs, connect 1/4" TS (Tip-Sleeve) phone plugs like this:

- Tip = + (hot)
- Sleeve = Ground

14. Stereo Line Ins (Ch. 3–4)

These fully-balanced inputs are designed for stereo or mono, balanced or unbalanced signals. They can be used with just about any professional or semi-pro instrument, effect or CD player.

Signals entering channel 3 are added to the left side of the main mix only. Signals entering channel 4 are added to the right.

When connecting a mono device, always use the left (mono) input (ch. 3) and plug nothing into the right input (ch. 4)—this way the signal will appear on both sides. This trick is called “jack normaling.”

15. Tape Assign to Main

Press this switch in to add the tape input to the main mix.

Press it out if you do not want the tape input to play in the main mix. This allows DJ-style cueing of the tape input [17] in your headphones before it is added to the main mix for your audience.

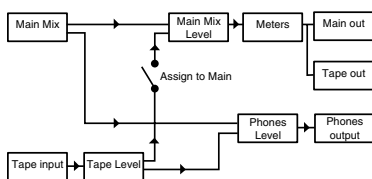

This also allows for overdubbing with the tape inputs/outputs without experiencing feedback, and it maintains isolation of your audio tracks. For example, you could be feeding the pre-recorded tracks from a computer into the tape inputs. Leave “assign to main” out so you can hear the pre-recorded tracks in the headphones, as you play along to them. Only your live performance will be recorded from the tape outputs, not the pre-recorded tracks. Press “assign to main” in if you want to play the completed songs in your main loudspeakers.

16. Tape Level

Use this to adjust the level of the tape input playing in the main mix and headphones.

17. Tape In

These dual, unbalanced RCA inputs accept line-level stereo signals. The signals entering the inputs are always routed to the phones output, and can be routed to the main output, depending on the position of the “assign to main” button.

Use these jacks for convenient playback of your mixes. You’ll be able to review a mix and then try another pass without repatching or disturbing the mixer levels. You can also use these jacks with an iPod dock, computer line-level audio output, or DVD player to feed music to a PA system between sets.

Use the “assign to main” switch [15] to add the tape input to the main mix, and use the tape level knob [16] to adjust its level.

18. Tape Out

These unbalanced RCA connections tap the main mix output to make simultaneous recording and PA work more convenient. Connect these to your recorder’s inputs.

The output here is an unbalanced copy of the main mix, and it is affected by the main mix level [22].

19. Phones

This stereo jack will drive any standard headphone to very loud levels. Ear buds or computer headphones may also be used with an appropriate adapter.

If you’re wiring your own cable for the headphones output, follow standard conventions:

Tip = Left channel

Ring = Right channel

Sleeve = Common ground

In the headphones, you will hear the main mix as well as any source playing in the tape inputs [17]. Adjust the phones level [21] knob for comfortable and safe listening levels in your headphones. See the warning on the next page before using headphones.

Adjusting the main mix level [22] will not affect the headphone output. Adjusting the tape level [16] will affect the level of the tape input signal heard in the headphones.

20. Phantom Power Switch

This global switch controls the phantom power supply for condenser microphones plugged into channel 1 and 2 mic [3] inputs. Press this in if your microphone requires phantom power. (The mixer can supply the microphone's power through the XLR connectors, using the same lines used for the audio.) Check with the microphone manufacturer if you are not sure. See the phantom power discussion on page 13 before using this switch.

Press the switch in to engage phantom power to both mic inputs. The LED next to the switch will illuminate when phantom is engaged. Press the switch again to turn it off.

21. Phones Level

This knob allows you to adjust the level of the signals going to the headphones.



WARNING: When we say the headphone amp is loud, we're not kidding. It can cause permanent ear damage. Even intermediate levels may be painfully loud with some headphones. **BE CAREFUL!** Always turn the phones knob all the way down before connecting headphones, or making any connections to the mixer. Keep it down until you've put the phones on. Then turn it up slowly.

22. Main Mix

This knob controls the levels of signals sent to the main outputs. All channels that are not turned fully down will wind up in the main mix.

Fully counterclockwise is off, the center is unity gain, and fully clockwise provides 12 dB of additional gain. This additional gain will typically never be needed, but once again, it's nice to know it's there.

This is the knob to turn down at the end of the song to achieve "The Great Fade-Out."

23. Power LED

This LED will illuminate when the mixer is turned on. It shows a general readiness of the mixer to do something wonderful to your musical world.

If the power switch [1] is off, or the power to the unit is turned off, then the LED will be off.

24. Meters

The 402VLZ4's peak metering system is made up of two columns of eight LEDs. It displays the signal level after the main mix level control [22].

Thanks to the 402VLZ4's wide dynamic range, you can get a good mix with peaks flashing anywhere between -12 and $+8$ dB on the meters. Most amplifiers clip at about $+10$ dB, and some recorders aren't so forgiving either. For best real-world results, try to keep your peaks between "0" and "+8".

Remember, audio meters are just tools to help assure you that your levels are "in the ballpark." You don't have to stare at them (unless you want to).

Congratulations! You've just read about all the features of the 402VLZ4. You're probably ready for a cold shower. Go ahead.

Appendix A: Service Information

If you think your 402VLZ4 has a problem, please check out the following troubleshooting tips and do your best to confirm the problem. Visit the support section of our website (www.mackie.com) where you will find lots of useful information such as FAQs, and other documentation. You may find the answer to the problem without having to send your mixer away.

Troubleshooting

Bad Channel

- Is the gain set correctly?
- Is the level knob turned up?
- Is the instrument switch set correctly? (Channels 1–2 only).
- Try the same source signal in another channel, set up exactly like the suspect channel.
- Check that the stereo pan switch is set correctly.
- Check the EQ and the low-cut switch.

Bad Output

- Is the associated level knob (if any) turned up?
- If it's a left main out, try unplugging the RCA left tape output. If the problem goes away, it's not the mixer.
- If a left speaker is presumed dead, switch the left and right cords, at the mixer's main outs. If the left speaker is still not working, it's not the mixer.

Noise

- Turn the channel level knobs down, one by one. If the sound disappears, it's either that channel or whatever is plugged into it, so unplug whatever that is. If the noise disappears, it's from your whatever.

Power

- The power LED on the mixer should come on when the power switch is on. Check that the power connection to the mixer is plugged in.

Repair

For warranty service, refer to the warranty information on page 23.

Non-warranty service is available at a factory-authorized service center. To locate the nearest service center, visit www.mackie.com, click "Contact Tech Support" and select "Locate a Service Center or Distributor" [3]. Service for a 402VLZ4 living outside the United States may be obtained through local dealers or distributors.

Need help with your mixer?

- Visit www.mackie.com and click 'Contact Tech Support' to find: FAQs, manuals, addendums, and other documents.
- Email us at: techmail@loudtechinc.com.

Appendix B: Connections

Balanced XLR Input Connector

The 402VLZ4 mixer has two female XLR inputs. Be sure the cables are wired per AES (Audio Engineering Society) standards:

Balanced XLR Input Connector

- Pin 1 – Shield (Ground)
- Pin 2 – Positive (+ or hot)
- Pin 3 – Negative (- or cold)

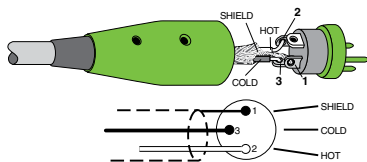

Balanced XLR Input Connector

Balanced 1/4" TRS Connector

TRS stands for Tip-Ring-Sleeve, the three connections available on a stereo 1/4" cable. This allows for a direct connection to the channel input jacks. Be sure the cables are wired per AES (Audio Engineering Society) standards:

Balanced 1/4" TRS Connector

- Sleeve – Shield (Ground)
- Tip – Positive (+ or hot)
- Ring – Negative (- or cold)

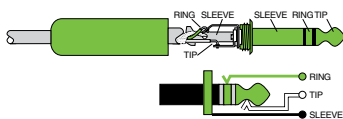

Balanced 1/4" TRS Connector

TRS jacks and plugs are used in several different applications:

- **Balanced mono circuits.** When wired as a balanced connector, a 1/4" TRS jack or plug is connected tip to signal high (hot), ring to signal low (cold), and sleeve to ground (earth).
- **Stereo headphones, and rarely, stereo microphones and stereo line connections.** When wired for stereo, a 1/4" TRS jack or plug is connected tip to left, ring to right and sleeve to ground (earth). VLZ4 mixers do not directly accept I-plug-type stereo microphones. They must be separated into a left cord and a right cord, which are plugged into the two mic preamps.

You can cook up your own adapter for a stereo microphone. "Y" two cables out of a female 1/4" TRS jack to two male XLR plugs, one for the right signal and one for the left.

Unbalanced 1/4" TS Connector

TS stands for Tip-Sleeve, the two connections available on a mono 1/4" cable. This allows for a direct connection to the channel input jacks. Be sure the cables are wired per AES (Audio Engineering Society) standards:

Unbalanced 1/4" TS Connector

- Sleeve – Shield (Ground)
- Tip – Positive (+ or hot)

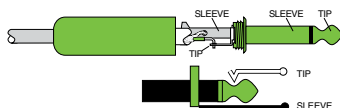

Unbalanced 1/4" TS Connector

TS jacks and plugs are used in many different applications, always unbalanced. The tip is connected to the audio signal and the sleeve to ground (earth). Some examples:

- Unbalanced microphones
- Electric guitars and electronic instruments
- Unbalanced line-level connections

Unbalanced RCA Connector

RCA-type plugs (also known as phono plugs) and jacks are often used in home stereo and video equipment and in many other applications. RCA plugs are unbalanced. Connect the signal to the center post and the ground (earth) or shield to the surrounding "basket." Be sure the cables are wired per AES (Audio Engineering Society) standards:

Unbalanced RCA Connector

- Sleeve – Shield (Ground)
- Tip – Positive (+ or hot)

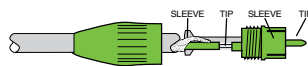

Unbalanced RCA Connector

Appendix C: Technical Information

Specifications

Main Mix Noise

(20 Hz–20 kHz bandwidth, 1/4" main out, channels 1–2 gain @ unity, channel EQs flat, stereo-pan button in.)

Main mix knob down, channel level knobs down: –103 dBu

Main mix knob unity, channel level knobs down: –98 dBu
(102 dB Signal to Noise Ratio, ref +4 dBu)

Main mix knob @ unity,
and channel level knobs @ unity: –92 dBu

Total Harmonic Distortion (THD)

(1 kHz @ 35 dB gain)

20 Hz–80 kHz bandwidth <0.005%

20 Hz–20 kHz bandwidth <0.003%

Attenuation (Crosstalk)

(1 kHz relative to 0 dBu, 20 Hz–20 kHz bandwidth, line in, 1/4" main out, gain @ unity.)

Main mix knob down: –70 dBu

Channel level knob down: –94 dBu

Frequency Response

Mic Input to Main Output (Gain @Unity)

+0, –1 dB, 20 Hz to 50 kHz

+0, –3 dB, <10 Hz to >100 kHz

Equivalent Input Noise (EIN)

(Mic in to main out, max gain.)

150 Ω termination: –128.5 dBu (20 Hz–20 kHz)

Common Mode Rejection Ratio (CMRR)

1 kHz: better than –70 dB

Maximum Levels

Mic in: +21 dBu

Tape in: +24 dBu

All other inputs: +22 dBu

All outputs: +22 dBu

Impedances

Mic in: 2.55 k Ω

Instrument input: 1 M Ω

All other inputs: 10 k Ω or greater

Tape out: 1.0 k Ω

Phones output: 60 Ω

All other outputs: 120 Ω

EQ

High Shelving \pm 15 dB @ 12 kHz

Low Shelving \pm 15 dB @ 80 Hz

Power Requirements

Power Consumption 8 watts

Input 100–240 V~, 50/60 Hz

Output 12.0 V DC, 2000 mA

External Power Supply 2-pin IEC 250 VAC

Temperature 0°–40°C // 32°–104°F

(H x W x D)

1.6" x 5.8" x 7.3" // 41 mm x 147 mm x 186 mm

Weight

With power supply 3.0 lb (1.36 kg)

Without power supply 2.5 lb (1.1 kg)

Since we are always striving to make our products better by incorporating new and improved materials, components, and manufacturing methods, we reserve the right to change these specifications at any time without notice.

The "Running Man" figure is a registered trademark of LOUD Audio, LLC. All other brand names mentioned are trademarks or registered trademarks of their respective holders, and are hereby acknowledged.

©2025 LOUD Audio, LLC. All Rights Reserved.



Correct disposal of this product. This symbol indicates that this product should not be disposed of with your household waste, according to the WEEE Directive (2012/19/EU) and your national law. This product should be handed over to an authorized collection site for recycling waste electrical and electronic equipment (EEE). Improper handling of this type of waste could have a possible negative impact on the environment and human health due to potentially hazardous substances that are generally associated with EEE. At the same time, your cooperation in the correct disposal of this product will contribute to the effective usage of natural resources. For more information about where you can drop off your waste equipment for recycling, please contact your local city office, waste authority, or your household waste disposal service.

Block Diagram

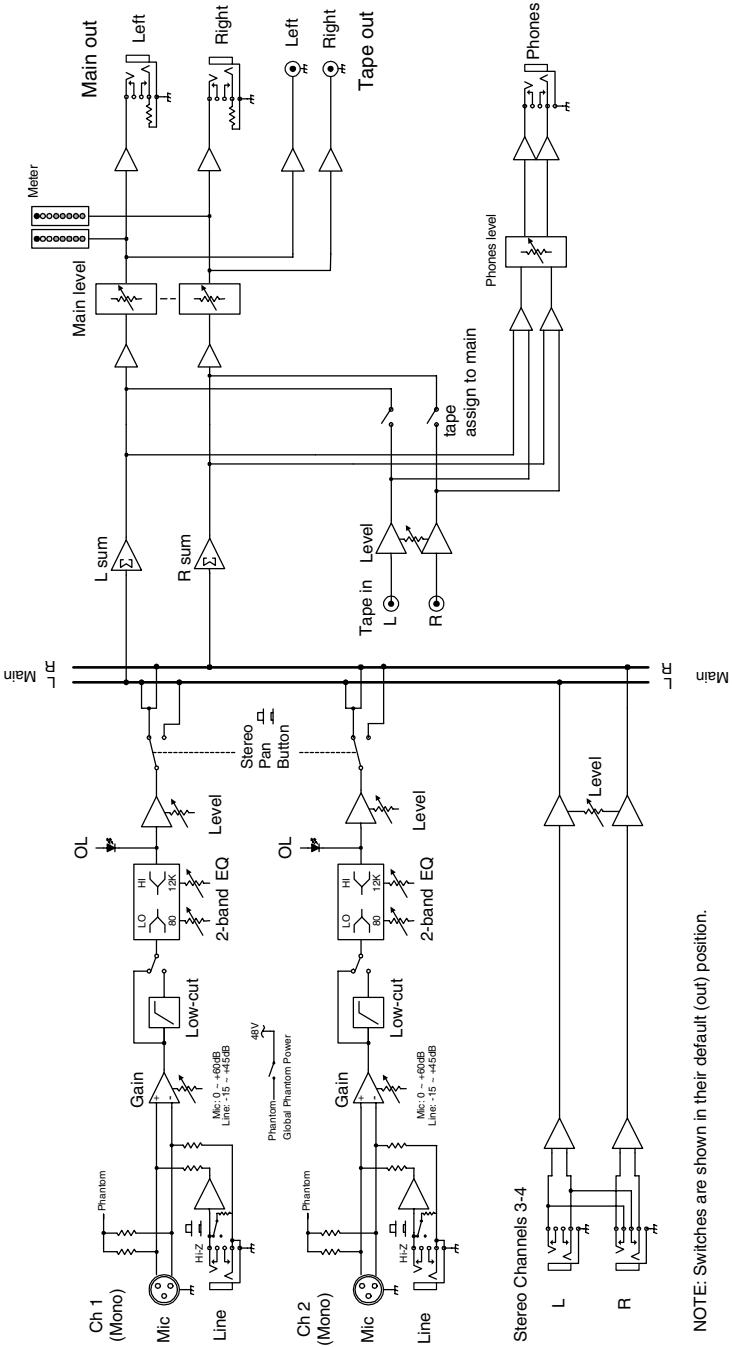

NOTE: Switches are shown in their default (out) position.

Dimensions

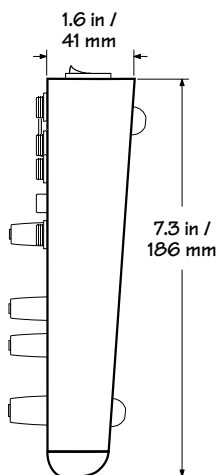
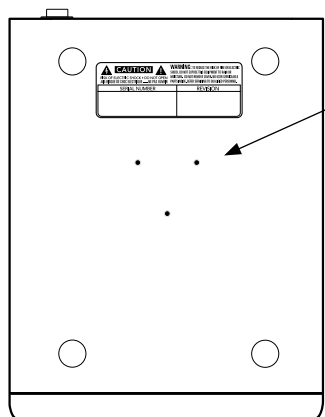
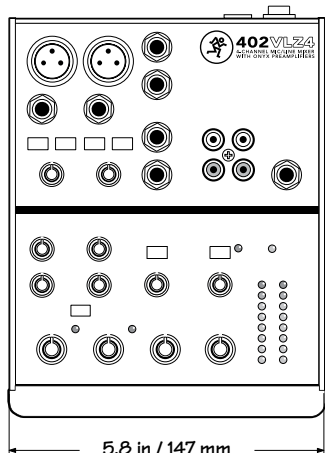
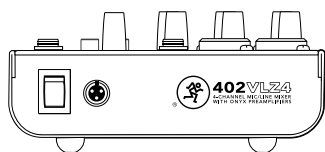

Microphone Stand

The bottom panel of the 402VLZ4 has three non-threaded holes that allow it to be fitted with an optional microphone stand adapter. This lets you support the mixer on a standard mic stand, and adjust its height and level to whatever suits your strangely-complex set of preferences.

1. Order the Atlas AD-IIB mic stand adapter, available from many a fine music store. (It is made and distributed by Atlas Sound.)
2. Use three Trilobular thread rolling screws 6-32 x 1/4" long to secure the adapter to the bottom of the 402VLZ4 [see below].



Do not use screws longer than 1/4", as these could damage the circuit boards. Do not use screws shorter than 1/4", or the adapter will not be securely fixed to the mixer.

3. Do not order the Atlas AD-II, as this is a pack of 100. If you do, please send for the informative booklet entitled 99 things to do with a mic stand adapter.

402VLZ4 Limited Warranty

Please keep your sales receipt in a safe place.

This Limited Product Warranty ("Product Warranty") is provided by LOUD Audio, LLC. ("LOUD") and is applicable to products purchased in the United States or Canada through a LOUD-authorized reseller or dealer. The Product Warranty will not extend to anyone other than the original purchaser of the product (hereinafter, "Customer," "you" or "your").

For products purchased outside the U.S. or Canada, please visit www.mackie.com, to find contact information for your local distributor, and information on any warranty coverage provided by the distributor in your local market.

LOUD warrants to Customer that the product will be free from defects in materials and workmanship under normal use during the Warranty Period. If the product fails to conform to the warranty then LOUD or its authorized service representative will at its option, either repair or replace any such nonconforming product, provided that Customer gives notice of the noncompliance within the Warranty Period to the Company at: www.mackie.com or by calling LOUD technical support at 1.800.898.3211 (toll-free in the U.S. and Canada) during normal business hours Pacific Time, excluding weekends or LOUD holidays. Please retain the original dated sales receipt as evidence of the date of purchase. You will need it to obtain any warranty service.

For full terms and conditions, as well as the specific duration of the Warranty for this product, please visit www.mackie.com.

The Product Warranty, together with your invoice or receipt, and the terms and conditions located at www.mackie.com constitutes the entire agreement, and supersedes any and all prior agreements between LOUD and Customer related to the subject matter hereof. No amendment, modification or waiver of any of the provisions of this Product Warranty will be valid unless set forth in a written instrument signed by the party to be bound thereby.



**19820 North Creek Parkway #201
Bothell, WA 98011 • USA
www.mackie.com**
