

# BIG KNOB

## STUDIO / STUDIO+

MONITOR CONTROLLER | INTERFACE

### OWNER'S MANUAL



# Important Safety Instructions

1. Read these instructions.
2. Keep these instructions.
3. Heed all warnings.
4. Follow all instructions.
5. Do not use this apparatus near water.
6. Clean only with a dry cloth.
7. Do not block any ventilation openings. Install in accordance with the manufacturer's instructions.
8. Do not install near any heat sources such as radiators, heat registers, stoves, or other apparatus (including amplifiers) that produce heat.
9. Do not defeat the safety purpose of the polarized or grounding-type plug. A polarized plug has two blades with one wider than the other. A grounding-type plug has two blades and a third grounding prong. The wide blade or the third prong are provided for your safety. If the provided plug does not fit into your outlet, consult an electrician for replacement of the obsolete outlet.
10. Protect the power cord from being walked on or pinched particularly at plugs, convenience receptacles, and the point where they exit from the apparatus.
11. Only use attachments/accessories specified by the manufacturer.
12. Use only with a cart, stand, tripod, bracket, or table specified by the manufacturer, or sold with the apparatus. When a cart is used, use caution when moving the cart/apparatus combination to avoid injury from tip-over.
13. Unplug this apparatus during lightning storms or when unused for long periods of time.
14. Refer all servicing to qualified service personnel. Servicing is required when the apparatus has been damaged in any way, such as power-supply cord or plug is damaged, liquid has been spilled or objects have fallen into the apparatus, the apparatus has been exposed to rain or moisture, does not operate normally, or has been dropped.
15. This apparatus shall not be exposed to dripping or splashing, and no object filled with liquids, such as vases or beer glasses, shall be placed on the apparatus.
16. Do not overload wall outlets and extension cords as this can result in a risk of fire or electric shock.
17. The MAINS plug or an appliance coupler is used as the disconnect device, so the disconnect device shall remain readily operable.



**CAUTION AVIS**

RISK OF ELECTRIC SHOCK. DO NOT OPEN  
RISQUE DE CHOC ELECTRIQUE. NE PAS OUVRIR

CAUTION: TO REDUCE THE RISK OF ELECTRIC SHOCK DO NOT REMOVE COVER (OR BACK) NO USER-SERVICEABLE PARTS INSIDE. REFER SERVICING TO QUALIFIED PERSONNEL.  
ATTENTION: POUR EVITER LES RISQUES DE CHOC ELECTRIQUE, NE PAS ENLEVER LE COUVERCLE. AUCUN ENTRETIEN DE PIÈCES INTERIEURES PAR L'USAGER. CONFIER L'ENTRETIEN AU PERSONNEL QUALIFIE.  
AVIS: POUR EVITER LES RISQUES D'INCENDIE OU D'ELECTROCUTION, N'EXPOSEZ PAS CET ARTICLE A LA PLUIE OU A L'HUMIDITE

The lightning flash with arrowhead symbol within an equilateral triangle is intended to alert the user to the presence of uninsulated "dangerous voltage" within the product's enclosure, that may be of sufficient magnitude to constitute a risk of electric shock to persons.  
Le symbole éclair avec point de flèche à l'intérieur d'un triangle équilatéral est utilisé pour alerter l'utilisateur de la présence à l'intérieur du coffret de "voltage dangereux" non isolé d'ampleur suffisante pour constituer un risque d'électrocution.

The exclamation point within an equilateral triangle is intended to alert the user of the presence of important operating and maintenance (servicing) instructions in the literature accompanying the appliance.  
Le point d'exclamation à l'intérieur d'un triangle équilatéral est employé pour alerter les utilisateurs de la présence d'instructions importantes pour le fonctionnement et l'entretien (service) dans le livret d'instruction accompagnant l'appareil.

18. This device complies with Part 15 of the FCC Rules. Operation is subject to the following two conditions: (1) this device may not cause harmful interference, and (2) this device must accept any interference received, including interference that may cause undesired operation.

Laite on liitettävä suojakoskettimilla varustettuun pistorasiaan.

Apparatet må tilkoples jordet stikkontakt.

Apparaten skall anslutas till jordat uttag.

**NOTE:** This equipment has been tested and found to comply with the limits for a Class B digital device, pursuant to part 15 of the FCC Rules. These limits are designed to provide reasonable protection against harmful interference in a residential installation. This equipment generates, uses, and can radiate radio frequency energy and, if not installed and used in accordance with the instructions, may cause harmful interference to radio communications. However, there is no guarantee that interference will not occur in a particular installation. If this equipment does cause harmful interference to radio or television reception, which can be determined by turning the equipment off and on, the user is encouraged to try to correct the interference by one or more of the following measures:

- Reorient or relocate the receiving antenna.
- Increase the separation between the equipment and the receiver.
- Connect the equipment into an outlet on a circuit different from that to which the receiver is connected.
- Consult the dealer or an experienced radio/TV technician for help.

**CAUTION:** Changes or modifications to this device not expressly approved by LOUD Audio, LLC. could void the user's authority to operate the equipment under FCC rules.

19. This device complies with FCC radiation exposure limits set forth for an uncontrolled environment. This device should be installed and operated with minimum distance 20cm between the radiator & your body.
20. This apparatus does not exceed the Class A/Class B (whichever is applicable) limits for radio noise emissions from digital apparatus as set out in the radio interference regulations of the Canadian Department of Communications.

**ATTENTION —** Le présent appareil numérique n'émet pas de bruits radioélectriques dépassant les limites applicables aux appareils numériques de class A/ de class B (selon le cas) prescrites dans le règlement sur le brouillage radioélectrique édicté par les ministere des communications du Canada.

21. This device complies with Industry Canada licence-exempt RSS standard (s). Operation is subject to the following two conditions:
  - (1) this device may not cause interference, and
  - (2) this device must accept any interference, including interference that may cause undesired operation of the device.

Le présent appareil est conforme aux CNR d'Industrie Canada applicables aux appareils radio exempts de licence. L'exploitation est autorisée aux deux conditions suivantes :

- (1) l'appareil ne doit pas produire de brouillage, et
- (2) l'utilisateur de l'appareil doit accepter tout brouillage radioélectrique subi, même si le brouillage est susceptible d'en compromettre le fonctionnement.

22. Exposure to extremely high noise levels may cause permanent hearing loss. Individuals vary considerably in susceptibility to noise-induced hearing loss, but nearly everyone will lose some hearing if exposed to sufficiently intense noise for a period of time. The U.S. Government's Occupational Safety and Health Administration (OSHA) has specified the permissible noise level exposures shown in the following chart.

According to OSHA, any exposure in excess of these permissible limits could result in some hearing loss. To ensure against potentially dangerous exposure to high sound pressure levels, it is recommended that all persons exposed to equipment capable of producing high sound pressure levels use hearing protectors while the equipment is in operation. Ear plugs or protectors in the ear canals or over the ears must be worn when operating the equipment in order to prevent permanent hearing loss if exposure is in excess of the limits set forth here:

Duration, per day in hours	Sound Level dBA, Slow Response	Typical Example
8	90	Duo in small club
6	92	
4	95	Subway Train
3	97	
2	100	Very loud classical music
1.5	102	
1	105	Matt screaming at Troy about deadlines
0.5	110	
0.25 or less	115	Loudest parts at a rock concert

**WARNING —** To reduce the risk of fire or electric shock, do not expose this apparatus to rain or moisture.

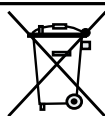

**Correct disposal of this product:** This symbol indicates that this product should not be disposed of with your household waste, according to the WEEE directive (2012/19/EU) and your national law. This product should be handed over to an authorized collection site for recycling waste electrical and electronic equipment (EEE). Improper handling of this type of waste could have a possible negative impact on the environment and human health due to potentially hazardous substances that are generally associated with EEE. At the same time, your cooperation in the correct disposal of this product will contribute to the effective usage of natural resources. For more information about where you can drop off your waste equipment for recycling, please contact your local city office, waste authority, or your household waste disposal service.

# Introduction

The Big Knob Studio and Big Knob Studio+ combine premium recording with the proven performance of the world's bestselling monitor controller.

Capture world-class recordings via dual Onyx™ preamps and professional studio features like zero-latency overdubbing and built-in talkback for artist communication.

Easily select from sources – including USB playback from your DAW – and switch between studio monitors.

Only Big Knob Studio and Big Knob Studio+ ensure balanced listening levels, offering independent gain trim on all inputs and outputs.

Two separate headphone outs are available, each with separate level control. Plus, there's even a handy front-panel input for your smartphone.

Big Knob Studio and Big Knob Studio+ are the ultimate compact studio solutions – just add monitors.

# Contents

- Important Safety Instructions ..... 2
- Introduction ..... 3
- Table Of Contents ..... 3
- Big Knob Features ..... 4
- Quick Start ..... 4
- Hookup Diagrams ..... 5
- A Quick Looksie at the Big Knob Studio Series ..... 7
- Rear Panel Description ..... 9
  - 1. Power Connector ..... 9
  - 2. Power Switch ..... 9
  - 3. USB Input / Output Jack ..... 9
  - 4. USB Rec Src Select Switch ..... 10
  - 5. XLR and 1/4" Combo Inputs ..... 10
  - Phantom Power ..... 10
  - 6. 1/4" Source Inputs ..... 11
  - 7. +4 dB / -10 dB Level Switch ..... 11
  - 8. Aux Mix | Cue In 1/4" Inputs [Big Knob Studio+] ..... 11
  - Internal Talkback Mic (on Top Panel) ..... 11
  - 9. Talkback Mic XLR Input [Big Knob Studio+] ..... 11
  - 10. Talkback Int / Ext Switch [Big Knob Studio+] ..... 12
  - 11. 1/4" Footswitch Jack [Big Knob Studio+] ..... 12
  - Outputs Overview ..... 12
  - 12. 1/4" 2-Track Outputs ..... 12
  - 13. +4 dB / -10 dB Level Switch ..... 13
  - 14. 1/4" Studio/Phones Amp Outputs [Big Knob Studio+] ..... 13
  - 15. 1/4" Monitor Outputs ..... 13

- Front Panel Description ..... 13
  - 16. 1/8" Stereo Line Input ..... 13
  - 17. 1/4" Phones Jacks ..... 13
- Top Panel Description ..... 14
  - 18. Mic/Line/Inst Gain Knobs ..... 14
  - 19. Trim Knobs ..... 14
  - 20. +48V Phantom Power Switch [Ch.1 and 2 Only] ..... 14
  - 21. Stereo Pan Switch [Ch.1-2] ..... 14
  - 22. Input / 2-Track Source Select Buttons ..... 14
  - 23. Cue Source Knob [Big Knob Studio+] ..... 15
  - 24. Direct Monitoring Knob ..... 15
  - 25. Phones Knobs and 2-Track / Cue Switches ..... 15
  - 26. Studio Outs On / Off Button ..... 15
  - 27. Studio Outs Level Knob ..... 15
  - 28. Input Meters ..... 16
  - 29. Volume Knob [aka Big Knob] ..... 16
  - 30. Mono Button ..... 16
  - 31. Mute Button ..... 16
  - 32. Dim Button ..... 16
  - 33. PWR / USB / +48V LEDs ..... 16
  - 34. Monitor Select Buttons ..... 17
  - 35. Trim Knobs ..... 17
  - 36. Talkback Level Knob ..... 17
  - 37. To 2-Track Button [Big Knob Studio+] ..... 17
  - 38. To Cue Button ..... 17
- Appendix A: Service Info ..... 18
  - Troubleshooting / Repair ..... 18
- Appendix B: Technical Information ..... 19
  - Big Knob Specifications ..... 19
  - Big Knob Dimensions ..... 20
  - Big Knob Block Diagrams ..... 22
- Big Knob Limited Warranty ..... 24



Like us



Follow us



Watch our dang videos

Part No. SW1192 Rev. C 07/23  
©2023 LOUD Audio, LLC. All Rights Reserved.

## Big Knob Features

- Professional source and monitor selection
  - o Choose between multiple sources and monitor pairs
  - o Classic Big Knob volume control
  - o Independent trim on all sources and monitor outs
  - o Mono, mute and dim functions
- Flexible USB recording interface
  - Big Knob Studio: 2x2
  - Big Knob Studio+: 2x4
  - o Two boutique-quality Onyx mic preamps including phantom power for condenser microphones
  - o High-resolution recording and playback 192 kHz / 24-bit
  - o Cue mix allows controlled blending of direct inputs with other signals for zero-latency recording
  - o Choice of recording paths provide flexibility for applications like podcasting
- Comprehensive feature set for professional studios
  - o Flexible source connections including convenient front panel 1/8" input for your smartphone
  - o Dual headphone outs with independent level control (and USB and Aux source options on the Big Knob Studio+)
  - o Built-in talkback mic for easy communication with artists
  - o Flexible talkback options including external mic input and footswitch control [Big Knob Studio+]
  - o Dedicated amp-driven studio output perfect for headphone distribution system [Big Knob Studio+]
  - o 16-segment high-resolution input source metering
- Sturdy "Built-Like-A-Tank" design
- Compatible with all major DAWs on both Mac and Windows
- Includes Tracktion® recording software

## Quick Start

We realize that you can't wait to hook up your Big Knob Studio / Studio+ and try it out. Nevertheless, please take the time to read this page NOW, and the rest can wait until you're good and ready.

1. PC users: install the latest driver. Mac users: no driver required.
2. Turn down all knobs.
3. Disengage all switches.
4. Plug signal sources into the Big Knob, such as:
  - Microphones plugged into the mic inputs. (Engage phantom power if needed.)
  - Line-level sources such as keyboards, drum machines, or MP3 players plugged into the line-level inputs.
  - Other stereo playback devices.
5. Connect cords from the monitor outs to powered speakers (or to an amplifier connected to passive speakers).
6. Push the USB cable securely into the Big Knob's USB connector and plug the other end into any open USB slot of the computer.
7. Push the threaded end of the power supply connector securely into the Big Knob's connector and rotate clockwise to lock. Plug the other end into a live AC outlet.
8. Turn the Big Knob on. Turn the powered studio monitors (or amplifiers) on. Turn the computer on.
9. Be sure that the volume of the input is the same as it would be during normal use.
10. Engage the desired input source select and monitor select switches.
11. Slowly bring up the volume knob to a comfortable listening level.

Please write your serial number here for future reference (i.e., insurance claims, tech support, return authorization, make dad proud, etc.)

Purchased at:

Date of purchase:

# Big Knob Studio Hookup Diagram

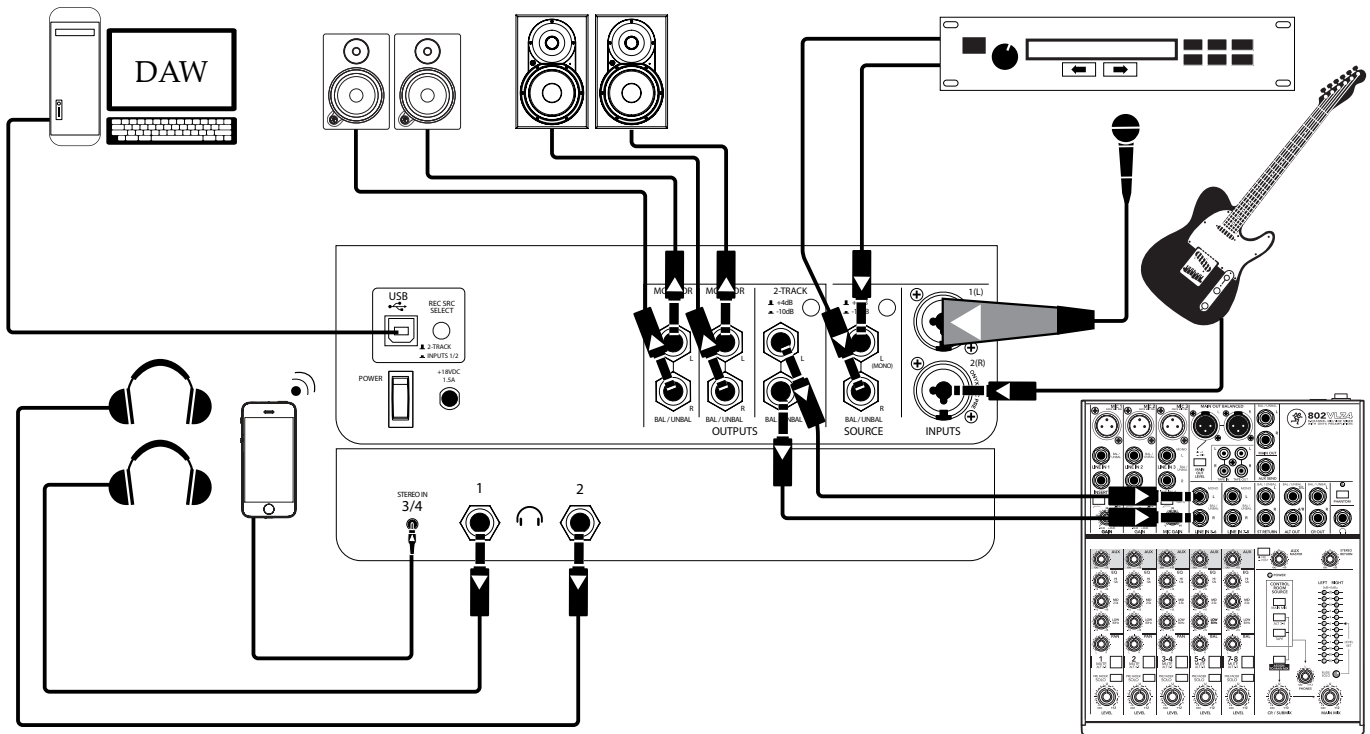

Don't be fooled... while the Big Knob Studio<sup>+</sup> may have a few more bells and whistles, the Big Knob Studio is no slouch! It, too, is packed with a ton of great features as outlined on the previous page. After you've found a good home for the Big Knob Studio, it's time to make all the connections.

In this example, a microphone is connected to XLR input 1 (L) and a guitar to 1/4" input 2 (R). The Source Input 3/4 jacks may accept 1/4" inputs (on the rear panel) and an 1/8" stereo input (on the front panel). They may be connected simultaneously, but not used simultaneously. If both inputs have connections, the 1/8" stereo line input will take priority over the 1/4" inputs. Here we hooked up a 2-track player to the 1/4" inputs and a smartphone to the 1/8" stereo line input jack.

The output section is as straightforward as the input section. Here we connected a pair of XR Series studio monitors to the Mon Output A L/R jacks and a pair of MR Series studio monitors to the Mon Output B L/R jacks. Additionally, two sets of headphones are connected to the two phones outputs on the Big Knob Studio's front panel and the 2-Track L/R output jacks are connected to the mixer's 1/4" L/R line input jacks. Lastly, a computer installed with your favorite DAW is connected to the USB port on the rear panel.

Now that connections have been made, the fun begins! The top panel has a variety of switches, buttons and something else... what was it? Oh yeah, a BIG knob, dead center! These allow you to select between the inputs, outputs, set levels and more. Descriptions of the Big Knob Studio features starts on page 9.

## Big Knob Studio+ Hookup Diagram

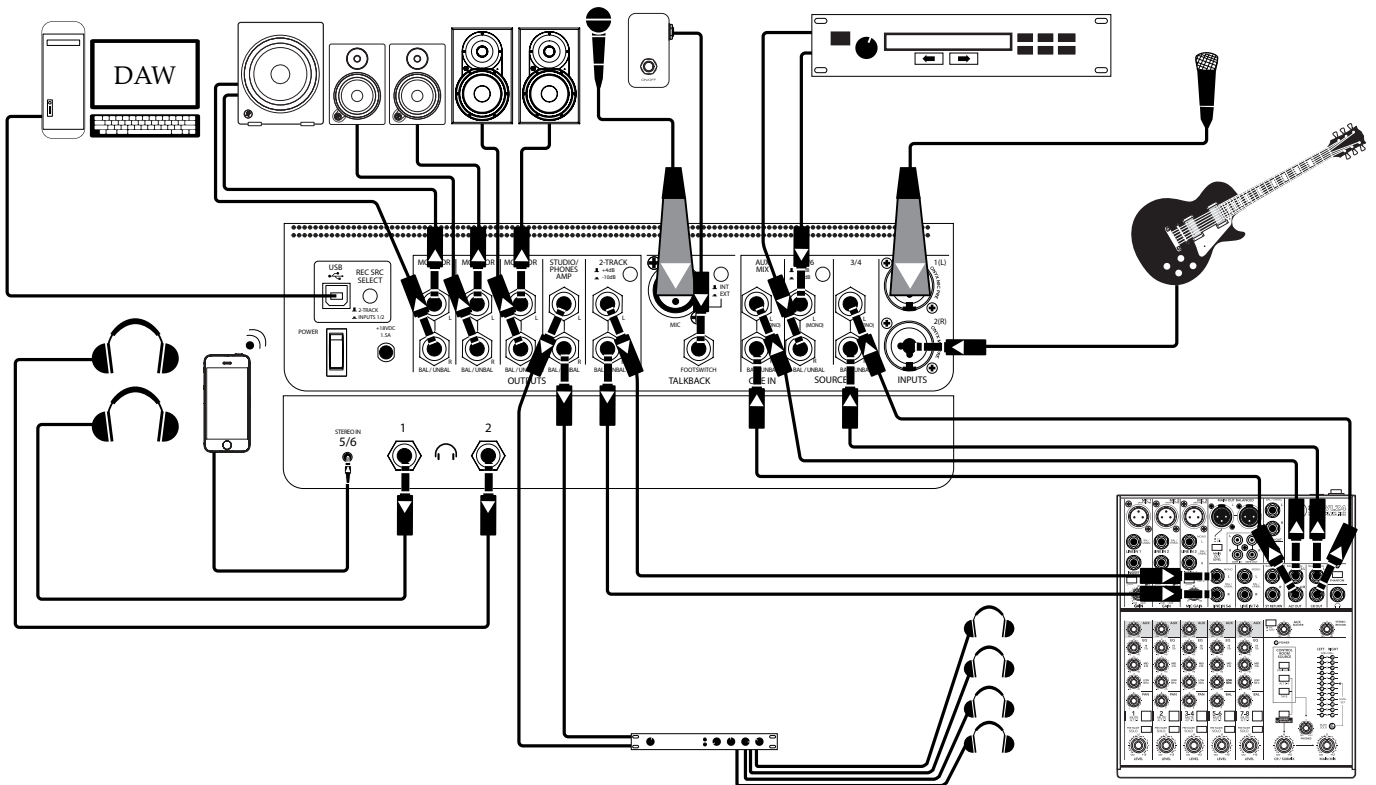

The Big Knob Studio+ is similar to the Big Knob Studio, but with a few more bells and whistles. No time to waste, let's get started! In this example, a microphone is connected to XLR input 1 (L) and a guitar to 1/4" input 2 (R). The Source Input 3/4 jacks are connected to an external mixer's Control Room (CR) output jacks, playing whatever sounds / sources are fed into the mixer. Likewise, the Cue In (Aux Mix) jacks are connected to the same mixer's Alt 3/4 output jacks.

Continuing on, the Source Input 5/6 jacks may accept 1/4" inputs (on the rear panel) and an 1/8" stereo input (on the front panel). They may be connected simultaneously, but not used simultaneously. If both inputs have connections, the 1/8" stereo line input will take priority over the 1/4" inputs. Here we hooked up a 2-track player to the 1/4" inputs and a smartphone to the 1/8" stereo line input jack.

Now onto the output section. Here we connected a pair of XR Series studio monitors to the Mon Output A L/R jacks, a pair of MR Series studio monitors to the Mon Output B L/R jacks and an MRS10 subwoofer to Mon Output C L/R jacks. A headphone amp with multiple sets of headphones is connected to the Studio / Phones Amp L/R output jacks. Additionally, two sets of headphones are connected to the two phones outputs on the Big Knob Studio+'s front panel.

The 2-Track L/R output jacks are connected to the mixer's 1/4" L/R line input jacks so signal may now be sent back and forth between the Big Knob Studio+ and mixer! Lastly, a computer installed with your favorite DAW is connected to the USB port on the rear panel.

Now that connections have been made, the fun begins! The top panel has a variety of switches, buttons and something else... what was it? Oh yeah, a BIG knob, dead center! These allow you to select between the inputs, outputs, set levels and more. Descriptions of the Big Knob Studio+ features starts on page 9.

### Typical Big Knob Studio+ Setup

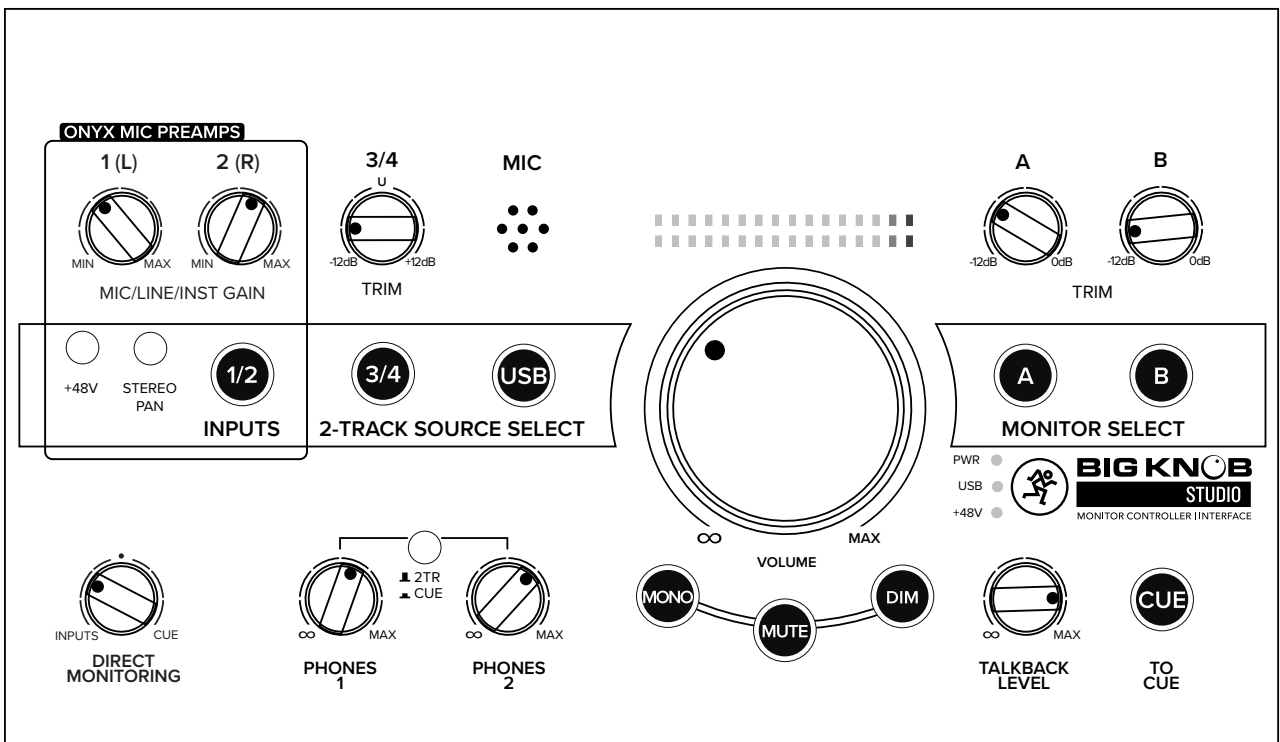
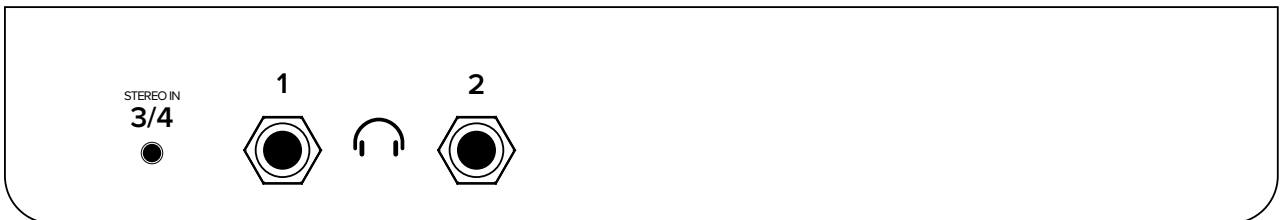
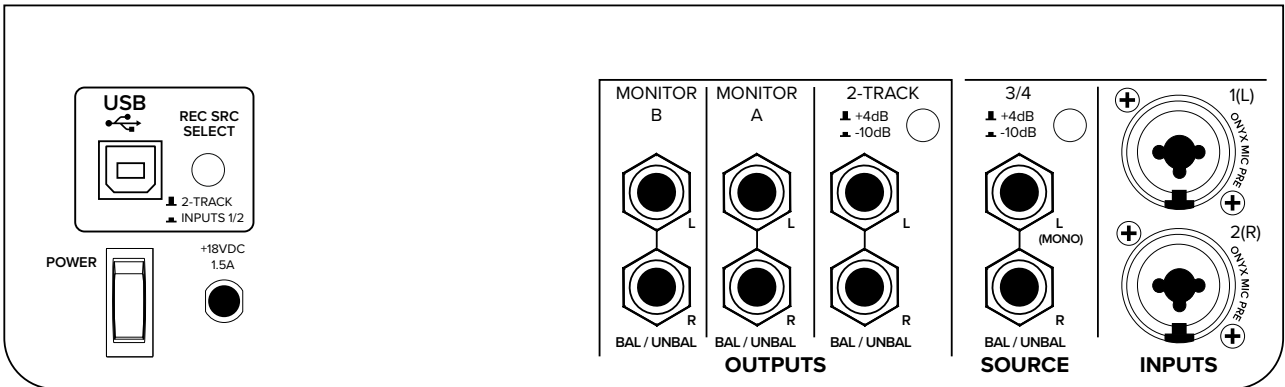

# Big Knob Studio+

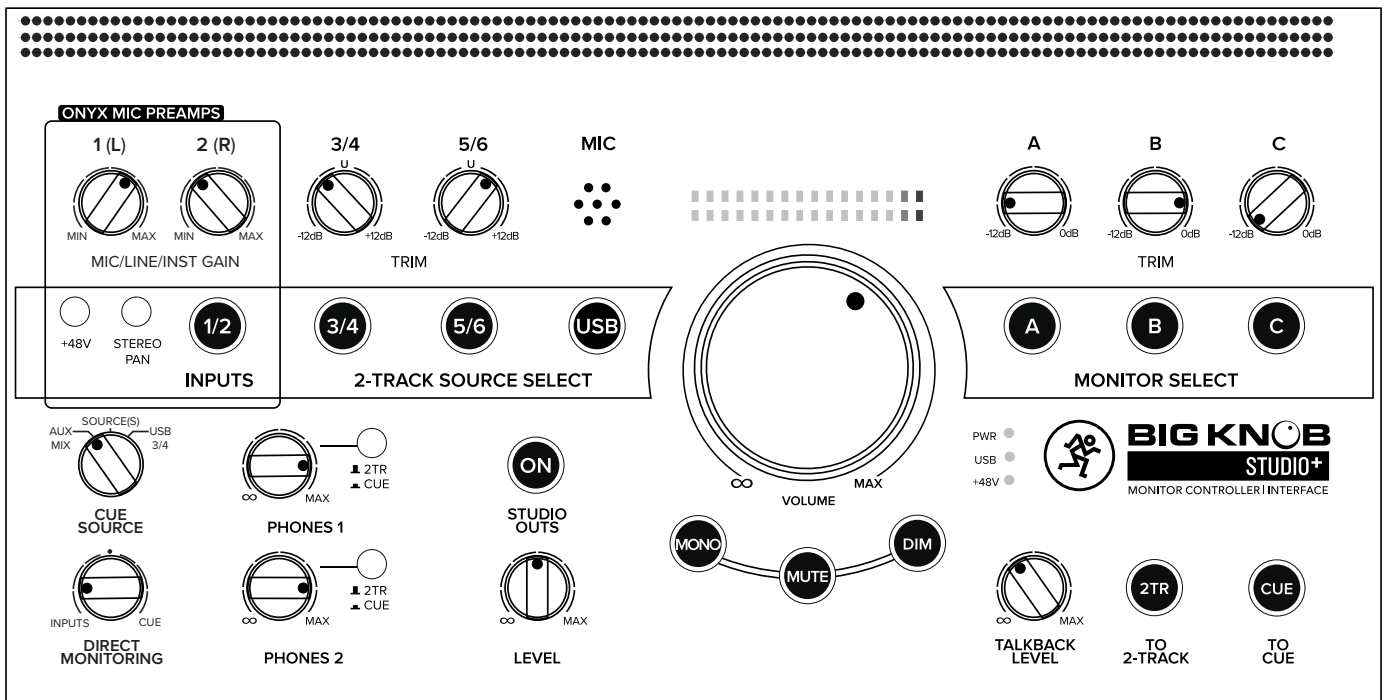
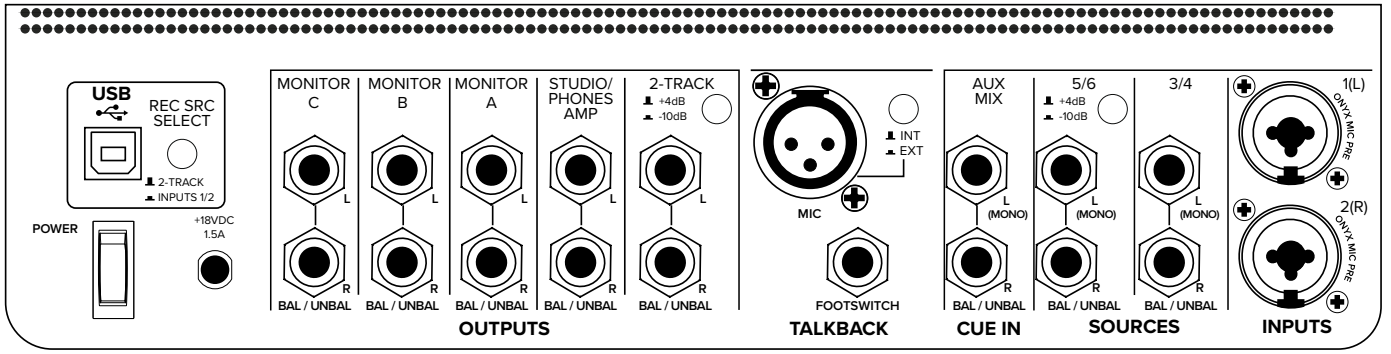



## Rear Panel Description

For the most part, the rear panel is where to connect various sources feeding **IN** to the Big Knob. These signals are then routed through the Big Knob and released through the **OUTPUT** jacks.

There are a few other bells and whistles, as well, and we'll take a look at all features, no matter how great or small. We should probably start with how to power the darn thing up first, though...!

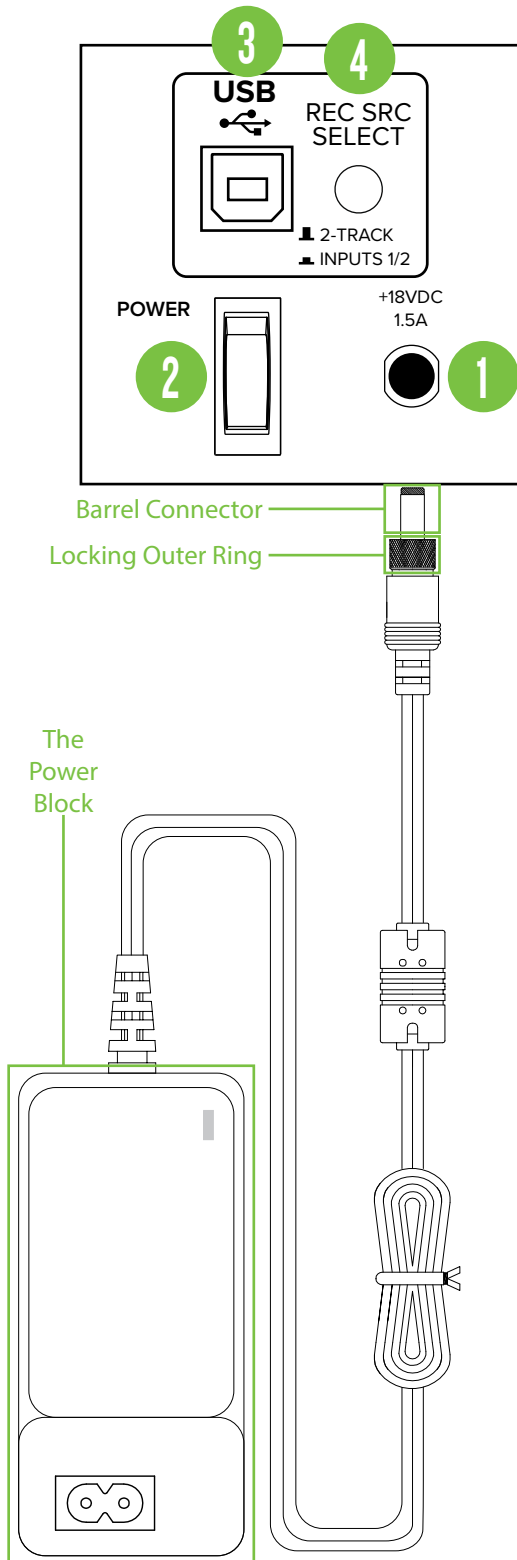

### I. Power Connector

The Big Knob Studio and Big Knob Studio+ have a universal external power supply that accepts any AC voltage ranging from 100 VAC to 240 VAC. No need for voltage select switches. It will work virtually anywhere in the world. That's why we call it a "Planet Earth" power supply! It is less susceptible to voltage sags or spikes compared to conventional power supplies, and provides greater electromagnetic isolation and better protection against AC line noise.

An external power supply [aka The Power Block] and a line cord are included with the Big Knob. A locking barrel connector resides at the end of the cord attached to The Power Block. Attach it to the power connector on the Big Knob and rotate the outer ring clockwise to lock. Do not over-tighten! Screw until there is resistance, then stop. Connect the female end of the line cord to The Power Block and plug the male end into a live grounded AC outlet. An LED on The Power Block will illuminate green to indicate success (whether the Big Knob is powered on or not).



Only use the factory-authorized power supply that came with your Big Knob.

### 2. Power Switch

Press the top of this rocker switch inwards to turn the Big Knob on and press the bottom of this rocker switch inwards to turn the Big Knob off.

### 3. USB Input / Output Jack

The built-in USB interface allows for some powerful and flexible routing by transferring digital audio to and from a computer. To use this feature with a PC, first download the PC ASIO driver from <http://mackie.com/products/big-knob-series>. If connecting to a Mac, it will show up as a 2x2 device [Big Knob Studio] or 2x4 device [Big Knob Studio+] with no driver required.

The USB routing of the Big Knob is a potent thing to behold. Input signals are always sent directly to the computer, yet also routable directly to the monitor and headphones outputs.

Similarly, stereo playback and/or the 2-track outputs are always routed back into the device for monitoring and overdubbing (unless you choose to mute them in software). Since the phones and monitor outputs have separate volume controls, users are free to monitor using either, neither or both. And because analog input signals may be blended in with playback signals for monitoring purposes, overdubs can occur in real-time without the burden of computer-induced latency.

#### 4. USB Rec Src Select Switch

You want options, you've got options! The Big Knob Studio and Big Knob Studio+ grant you the opportunity to choose between recording paths for a multitude of applications, one of which is yours!

This two-position latching switch simply allows you to choose which USB source you would like to use for recording:

With the switch disengaged [2-track], the signal at the 2-track and monitor outputs is recorded. In other words, the signal seen at the USB inputs is a mirror image of the 2-track signal.

With the switch engaged [inputs 1/2], only the Onyx mic preamps – channels 1 and 2 – are delivered to the DAW via USB sends 1/2.

#### 5. XLR and 1/4" Combo Inputs

These dual Onyx Wide-Z preamps accept both balanced microphone inputs from an XLR connector and balanced and unbalanced line-level inputs from a 1/4" TRS connector. The microphone preamps feature our Onyx design, with higher fidelity and headroom rivaling any standalone mic preamp on the market today.

They are wired as follows, according to standards specified by the AES (Audio Engineering Society).

##### Balanced XLR Wiring:

Shield (Ground)	Pin 1
Hot (+)	Pin 2
Cold (-)	Pin 3

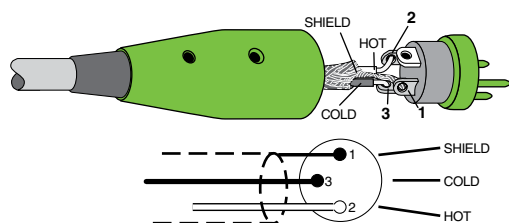

#### Phantom Power

Most modern professional condenser mics require 48V phantom power, which lets the interface send low-current DC voltage to the mic's electronics through the same wires that carry audio. (Semi-pro condenser mics often have batteries to accomplish the same thing.) "Phantom" owes its name to an ability to be "unseen" by dynamic mics (Shure SM57/SM58, for instance), which don't need external power and aren't affected by it anyway.

Phantom power may be selected by depressing the Big Knob's phantom power switch on the top panel.



Never plug single-ended (unbalanced) microphones, or ribbon mics into the mic input jacks if phantom power is on. Do not plug instrument outputs into the mic XLR input jacks with phantom power on, unless you are certain it is safe to do so. Be sure the channel's gain control is turned down when connecting microphones to the mic inputs when phantom power is turned on, to prevent pops from getting through to the speakers.

The 1/4" jacks share circuitry (but not phantom power) with the mic preamps, and can be driven by balanced or unbalanced sources.

Additionally, both channels may accept Hi-Z sources (such as guitars) via the 1/4" input without the need for a separate DI box.

- Unbalanced TS (tip-sleeve) lines can be accommodated via the TRS jack. Make sure the cable terminates with a TS plug (like a guitar plug), or if it's a TRS plug (such as a headphone plug), make sure the ring is tied to the sleeve and that the plug is fully inserted into the jack. These inputs are mono-summing (to both busses), but stereo when the stereo pan switch (located on the top panel) is engaged. This way, L/R mono operation may be used for mics and instruments or stereo for everything else.

The connectors are wired as follows, according to standards specified by the AES (Audio Engineering Society).

##### Balanced 1/4" TRS

Hot (+)	Tip
Cold (-)	Ring
Shield (Ground)	Sleeve

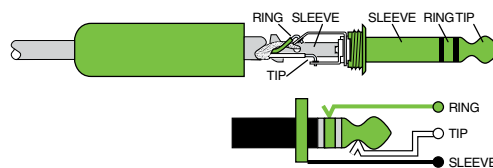

Balanced 1/4" Connectors

##### Unbalanced 1/4" TS

Hot (+)	Tip
Shield (Ground)	Sleeve

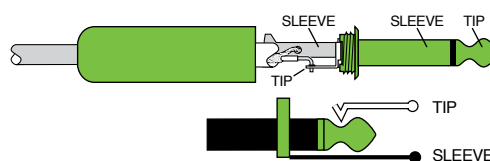

Unbalanced 1/4" Connectors



NEVER connect the output of an amplifier directly to a Big Knob's input jack. This could damage the input circuitry and we wouldn't want that now, would we?

## 6. 1/4" Source Inputs

Connect the L/R line-level signals from the source(s) to the 1/4" source input jack(s).

- The source input connectors accept balanced or unbalanced signals.
- Unbalanced TS (tip-sleeve) lines can be accommodated via the TRS jack. Make sure the cable terminates with a TS plug (like a guitar plug), or if it's a TRS plug (such as a headphone plug), make sure the ring is tied to the sleeve and that the plug is fully inserted into the jack. The left TRS inputs are mono-summing (to both busses), but stereo when cables are connected to the left and right inputs.

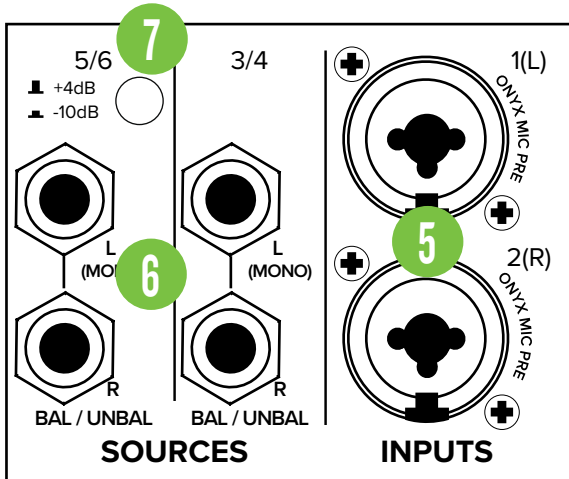

These 1/4" connectors are wired the same as the combo input connectors as seen on the previous page.



There is an 1/8" stereo line input on the front panel of both the Big Knob Studio and Big Knob Studio+. The 1/4" and 1/8" line-level connections may be connected simultaneously, but not used simultaneously. If they are connected simultaneously, the 1/8" stereo line input will take priority over the listed 1/4" connection [3/4 on the Big Knob Studio, 5/6 on the Big Knob Studio+].



The Big Knob Studio has one pair of 1/4" source input jacks while the Big Knob Studio+ possesses an additional pair.

## 7. +4 dB / -10 dB Level Switch

This two-position switch sets the level of the source inputs to either +4 dB (balanced input, switch disengaged) or -10 dB (unbalanced input, switch engaged). Use the +4 dB setting for professional equipment operating at the +4 dBu standard and use the -10 dB setting for consumer equipment operating at the -10 dBV standard.



This switch sets the level for source inputs 3/4 on the Big Knob Studio and source inputs 5/6 on the Big Knob Studio+.

## 8. Aux Mix | Cue In 1/4" Inputs [Big Knob Studio+]

These 1/4" inputs are extremely powerful! Our favorite way to utilize them is by connecting the L/R outputs of an analog mixer to these L/R line-level input jacks. This way, multiple inputs (from the mixer) are all dialed into a stereo pair into the L/R aux mix | cue in jacks.

Another possibility is connecting the outputs of a soundcard to these inputs. Basically, any alternate mix in from an external source is possible! This provides the artist with a separate mix and may be thought of as USB channels 3/4.

- The aux mix | cue in input connectors accept balanced or unbalanced signals.
- Unbalanced TS (tip-sleeve) lines can be accommodated via the TRS jack. Make sure the cable terminates with a TS plug (like a guitar plug), or if it's a TRS plug (such as a headphone plug), make sure the ring is tied to the sleeve and that the plug is fully inserted into the jack. The left TRS inputs are mono-summing (to both busses), but stereo when cables are connected to the left and right inputs.

These 1/4" connectors are wired the same as the 1/4" and combo input connectors seen previously.

## Internal Talkback Mic (on Top Panel)

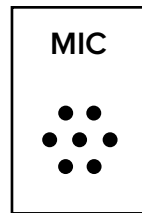

The built-in talkback microphone is located on the Big Knob's top panel between the trim knobs and input meters. It is an omni-directional dynamic microphone, and will pick up your voice from anywhere in front of the Big Knob. It's activated when a talkback assign button is pressed [To 2-Track, To Cue].

## 9. Talkback Mic XLR Input [Big Knob Studio+]

This XLR connector may accept a balanced external dynamic mic for talkback. It is wired as follows, according to standards specified by the AES (Audio Engineering Society).

### Balanced XLR Wiring:

Shield (Ground)	Pin 1
Hot (+)	Pin 2
Cold (-)	Pin 3

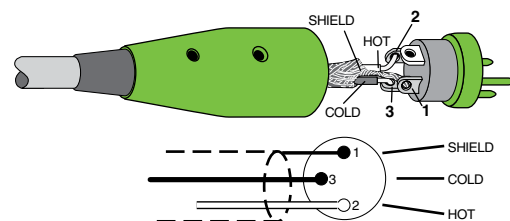

The talkback level is controlled by the Talkback knob. Because the talkback knob is located on the top panel of the Big Knob Studio+, it will be described in more detail in that section.

### 10. Talkback Int / Ext Switch [Big Knob Studio+]

If you are in a noisy environment, the built-in talkback mic may not work as well because it picks up the ambient noise as well as your voice. You will probably have better results if you use an external microphone that you can talk directly into.

If you are using an external mic, you must push in the external mic switch. When the switch is out, the built-in talkback mic is used, regardless of whether or not you have an external mic plugged in. When the switch is pushed in, the built-in mic is disconnected and only the external mic is used.

### 11. 1/4" Footswitch Jack [Big Knob Studio+]

This unbalanced 1/4" TRS connector is where to connect your favorite footswitch. This allows you to easily enable or disable talkback at will. Talkback will be routed to both the cue and 2-track outputs. Additional information about talkback routing may be found on page 17.

Any momentary one-button on / off footswitch will work. A momentary switch means that talkback is always on when the footswitch is engaged and held.



Make sure the talkback switch is disengaged so you can poke fun at the band without them hearing you.

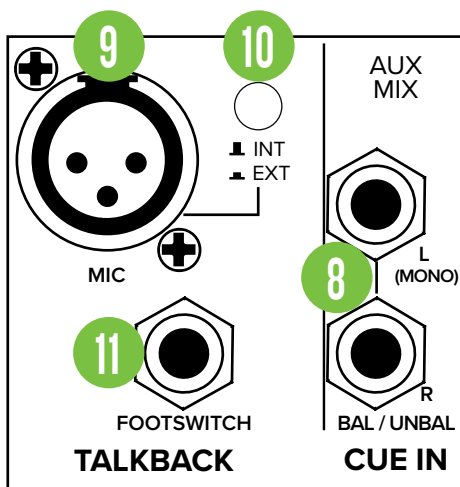

### Outputs Overview

All Big Knob outputs are 1/4" L/R connectors that may be distributed to a variety of inputs as outlined on the right.

The studio / phones amp outputs have separate volume controls, but the 2-track and monitor outputs are fed by the "control room bus." This is the signal path fed from the input currently selected with the source select button and routed through the volume knob.

- All output connectors accept balanced or unbalanced signals.
- Unbalanced TS (tip-sleeve) lines can be accommodated via the TRS jack. Make sure the cable terminates with a TS plug (like a guitar plug), or if it's a TRS plug (such as a headphone plug), make sure the ring is tied to the sleeve and that the plug is fully inserted into the jack.

The connectors are wired as follows, according to standards specified by the AES (Audio Engineering Society).

#### Balanced 1/4" TRS

Hot (+)	Tip
Cold (-)	Ring
Shield (Ground)	Sleeve

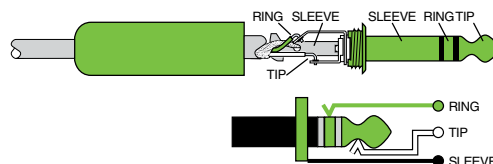

Balanced 1/4" Connectors

#### Unbalanced 1/4" TS

Hot (+)	Tip
Shield (Ground)	Sleeve

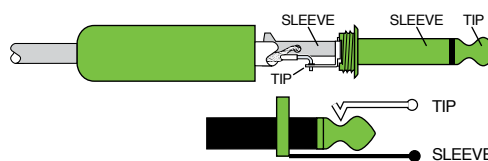

Unbalanced 1/4" Connectors

### 12. 1/4" 2-Track Outputs

Connect the L/R 2-track outputs to the inputs of a 2-track recorder. This could be a DAT deck, cassette deck, reel-to-reel recorder, etc.

### 13. +4 dB / -10 dB Level Switch

This two-position switch sets the level of the 2-track outputs to either +4 dB (balanced output, switch disengaged) or -10 dB (unbalanced output, switch engaged). Use the +4 dB setting for professional equipment operating at the +4 dBu standard and use the -10 dB setting for consumer equipment operating at the -10 dBV standard.

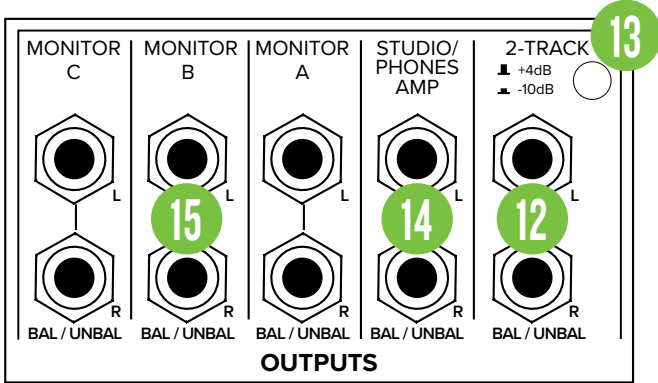

### 14. 1/4" Studio/Phones Amp Outputs [Big Knob Studio+]

Connect the L/R studio / phones amp outputs to EITHER...

...(1) the inputs of powered studio monitors (or to a power amplifier driving passive speakers) in the studio performance space. This allows the performers to hear playback without having to use headphones and allows the control room engineer to communicate to the performers through the talkback system. The studio outs level is controlled by the studio outs level control on the front panel...

...OR (2) the inputs of an external multi-headphone amplifier. This allows you to connect multiple sets of headphones for the talent. The phones amp output level is not affected by the volume knob or the headphone level controls on the top panel. The headphone amplifier should have its own individual volume controls for the headphones.

### 15. 1/4" Monitor Outputs

Connect the L/R monitor outputs to the inputs of powered studio monitors or to a power amplifier driving passive speakers. These outputs deliver the main balanced stereo signal (as determined by the engaged input selections).



The Big Knob Studio has two pairs of 1/4" monitor output jacks while the Big Knob Studio+ possesses an additional pair.

## Front Panel Description

The front panel may not have a ton of features – there are only two – but we're confident that the features provided will be used often for years to come. That said, we better take a look!

### 16. 1/8" Stereo Line Input

The stereo line input may accept an 1/8" line-level signal from a smartphone, MP3 player, or other signal source.



There are 1/4" inputs on the rear panel of both the Big Knob Studio and Big Knob Studio+. The 1/4" and 1/8" line-level connections may be connected simultaneously, but not used simultaneously. If they are connected simultaneously, the 1/8" stereo line input will take priority over the listed 1/4" connection [3/4 on the Big Knob Studio, 5/6 on the Big Knob Studio+].

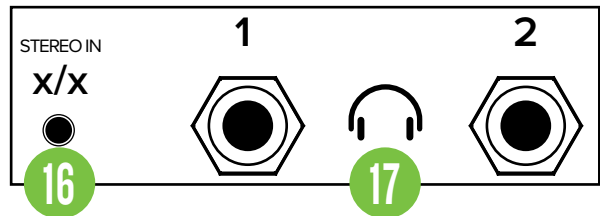

### 17. 1/4" Phones Jacks

These 1/4" TRS connectors supply the output to stereo headphones. The volume is controlled with the phones knobs located on the top panel. The signal sent to these jacks is dependent on the position of the 2TR / CUE switch as described on the following page.

The phones output follows standard conventions:

Left channel	Tip
Right channel	Ring
Ground	Sleeve

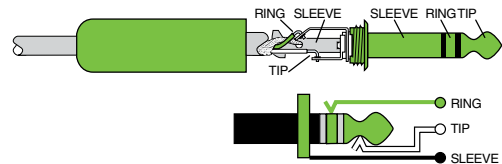

Balanced 1/4" Connectors



The headphone amp is loud and could cause permanent hearing damage. Even intermediate levels may be painfully loud with some headphones. **BE CAREFUL!** Always turn the phones knob all the way down before connecting headphones or doing anything new that may affect the headphone volume. Then turn it up slowly as you listen carefully.

## Top Panel Description

On to the top panel...and this is where the magic happens! Once all of the connections on the rear and front panels have been made, there are several knobs, switches, buttons and volume control that you may use, manipulate and set to heart's content. There are also some LEDs, but those can't be manipulated, only illuminated! Please read on...

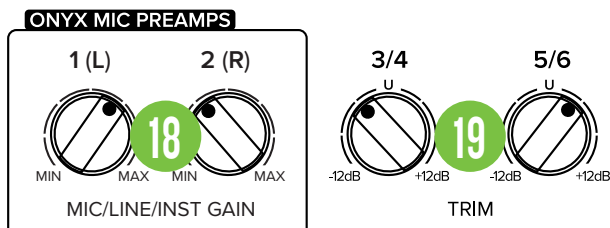

### 18. Mic/Line/Inst Gain Knobs

The gain knobs adjust the input sensitivity of the mic and line inputs. This allows signals from the outside world to be adjusted to run through each input at optimal internal operating levels.

### 19. Trim Knobs

The trim knobs adjust the input sensitivity of the incoming 2-track source signal by  $\pm 12$  dB (unity at center detent). This allows for precise level matching between the various incoming 2-track sources, which often do not have output level controls of their own.



In addition to the aforementioned Onyx mic preamp gain knobs [1(L), 2(R)], the Big Knob Studio has one trim knob [3/4] while the Big Knob Studio+ possesses an additional trim knob [3/4, 5/6].

### 20. +48V Phantom Power Switch [Ch. 1 and 2 Only]

Most modern professional condenser mics require 48V phantom power, which lets the interface send low-current DC voltage to the mic's electronics through the same wires that carry audio. (Semi-pro condenser mics often have batteries to accomplish the same thing.) "Phantom" owes its name to an ability to be "unseen" by dynamic mics (Shure SM57/SM58, for instance), which don't need external power and aren't affected by it anyway.

Press this switch in if your microphone requires phantom power. (Always check the position of this switch before connecting microphones.) An LED located near the bottom right of the Big 'volume' Knob and left of the Big Knob logo will illuminate green to indicate that phantom power is active. This switch only affects channels 1-2.



Never plug single-ended (unbalanced) microphones, or ribbon mics into the mic input jacks if phantom power is on. Do not plug instrument outputs into the mic XLR input jacks with phantom power on, unless you know for certain it is safe to do so. Be sure the channel's gain control is turned down when connecting microphones to the mic inputs when phantom power is turned on, to prevent pops from getting through to the speakers.

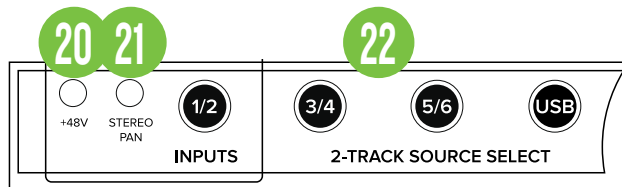

### 21. Stereo Pan Switch [Ch. 1-2]

With this switch pressed in, channel 1 will play only in the left side of the main mix, and channel 2 will play in the right side. Conversely, with this switch out, each mono channel feeds both the left and right sides of the main mix equally. For example:

- **Playing a mono source:** If you talk into a microphone connected to input 1, your sweet tones will be heard in both the left and right monitors.
- **Overdubbing a mono source:** if you are monitoring directly through the headphones, you can hear the overdub signal in both ears while you are playing.

Record output, however, is not affected by the position of the switch. Channel 1 will always feed the recording USB / analog left output and channel 2 will always feed the recording USB / analog right output.

The stereo pan switch does not affect the other channels or USB.

### 22. Input / 2-Track Source Select Buttons

These buttons turn the input signals connected to Big Knob on and off. Engaged buttons route the associated inputs to the engaged monitor outputs. Any combination of inputs may be turned on simultaneously. Engaged buttons will illuminate green.

Engaged source select buttons route the associated inputs to the engaged monitor stereo outputs, the 2-track stereo output, to the studio stereo output (if the studio outs button is engaged) or phones amp stereo output (if the studio outs button is disengaged) and to the phones 1 and 2 outputs located on the front panel.

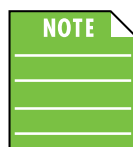

The Big Knob Studio has three source select buttons [1/2, 3/4, USB] while the Big Knob Studio+ possesses an additional source select button [1/2, 3/4, 5/6, USB].



**A Cautionary Note:** When you have a 2-track recording device connected to both the inputs and the outputs on Big Knob, you run the risk of creating a feedback loop. If the recording device is in record, record pause, or input monitor mode, the signal can go from the 2-track outputs through the recording device and back into the 2-track inputs, creating a circular loop that results in a terrible howl.

You must remember to turn off the appropriate 2-track input source select button when recording to your 2-track recorder!

### 23. Cue Source Knob [Big Knob Studio<sup>+</sup>]

The Big Knob Studio<sup>+</sup> has a 3-position blend knob that allows you to select which input source(s) level is controlled via the direct monitoring knob (as described below).

Knob position (L, C, R):

- Left – Only the aux mix inputs will be heard.
- Center – A masterful concoction of the aux mix inputs, USB and inputs 3/4 will be heard...also known as “a blend”. And you didn’t think we made blenders!
- Right – Only USB outputs 3/4 – the return from the DAW – will be heard.

### 24. Direct Monitoring Knob

The direct monitoring knob adjusts the level of inputs 1/2 [Big Knob Studio] and Cue Source selection [as described above, Big Knob Studio<sup>+</sup>] to be delivered to the phones and studio outputs. As an added bonus, this is all at zero-latency!

Knob position (L, C, R):

- Full Left – Input 1/2 = Full Volume  
Cue Source = No Volume
- Center – Input 1/2 and Cue Source = Equal Volume
- Full Right – Input 1/2 = No Volume  
Cue Source = Full Volume

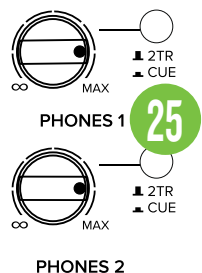
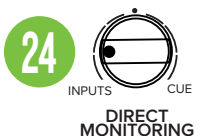

### 25. Phones Knobs and 2-Track / Cue Switch(es)

The phones knobs are used to adjust the volume from the phones output jacks, from off (∞) to maximum gain (MAX).



The headphone amp is loud and could cause permanent hearing damage. Even intermediate levels may be painfully loud with some headphones. **BE CAREFUL!** Always turn the phones knob all the way down before connecting headphones or doing anything new that may affect the headphone volume. Then turn it up slowly as you listen carefully.

The accompanying 2-track / cue switch(es) control the location of where the headphones is receiving its source path.

Switch disengaged [up] – Phones receives the source from the main output signal path, post-summing / pre-volume.

Switch engaged [down] – Phones receives the same signal as the studio outputs.



This feature allows you to choose between hearing what is selected on the input source section or what the musicians hear in the cue mix.



The Big Knob Studio has one 2-track / cue switch while the Big Knob Studio<sup>+</sup> possesses an additional switch, one for each phones knob.



### 26. Studio Outs On / Off Button [Big Knob Studio<sup>+</sup>]

This button turns the signal path on and off going to the studio outs jacks on the rear panel. The button will illuminate white when engaged (on).

### 27. Studio Outs Level Knob [Big Knob Studio<sup>+</sup>]

The studio outs level knob is used to adjust the volume from the studio output jacks on the rear panel, from off (∞) to maximum gain (MAX).

## 28. Input Meters

These meters show the signal level of the currently selected stereo source (es). They are made up of two columns of 16 LEDs with three colors to indicate different ranges of signal level, sideways traffic light style.

For best real-world results, try to keep your peaks bouncing between the green and yellow LEDs, the colors of our beloved hometown Seattle Supersonics [RIP].

The red LEDs indicate clipping. Clipping creates undesirable distortion and should be avoided at all costs. If the red LEDs illuminate frequently, turn the gain/trim knobs down.

Remember, audio meters are just tools to help assure you that your levels are “in the ballpark.” You don’t have to stare at them (unless you want to).

## 29. Volume Knob [aka Big Knob]

Here we are with the money maker! The volume knob – aka Big Knob – adjusts the volume of the selected input source’s signal going to the selected monitor outputs. The volume knob ranges from OFF ( $\infty$ ) to unity (MAX).



**WARNING:** Always turn the volume knob all the way down before making connections or trying something new. Keep it down until all changes have been made, then turn it up slowly. This saves your speakers – and more importantly, your ears – from blowing.

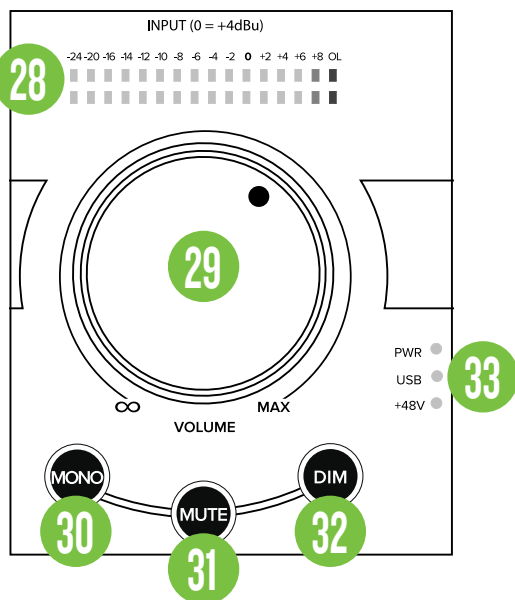

## 30. Mono Button

Mono is short for mononucleosis. It is an infection that typically leads to a feeling of tiredness, although one could also get headaches, a sore throat, swollen glands and more. Thankfully, engaging the mono button here does not produce the infection. Rather, the mono here is short for monophonic.

Pressing the mono button combines the stereo signal into a monophonic signal at the monitor outputs. The left and right input signals are summed and the mono signal is output at both the left and right outputs. This allows you to check for phase problems in the stereo signal when played over a monophonic system. The button will illuminate white when engaged.

## 31. Mute Button

The mute button does just what it sounds like it does. It turns off the signal at the monitor outputs by “routing” it into oblivion. Engaging the mute button (almost) provides the same result as turning the volume knob all the way down. The button will illuminate white when engaged.

## 32. Dim Button

Pressing this button turns down the signal going to the monitor outputs by 20 dB. This allows you to essentially “turn down” the speakers to converse without affecting the speaker level. The button will illuminate white when engaged.

## 33. PWR / USB / +48V LEDs

The PWR LED will illuminate green when the power switch is turned on and the power cord is connected to an active AC Mains supply. If it does not turn on, make sure the power cord is correctly connected at both ends, the local AC mains supply is active, and the power switch is on.

The USB LED will illuminate green when the computer is powered on and connected successfully and securely (via USB) to the Big Knob. Different from the power LED, the USB light informs you that the device is “enumerated”, and in a functional and happy state.

The +48V LED will illuminate green when the phantom power switch is turned on. Phantom power only affects mic channels 1-2.



### 34. Monitor Select Buttons

These buttons turn the output signals connected to Big Knob on and off. Press these buttons to route the currently selected input source(s) to the currently selected monitor output jacks. Engaged buttons will illuminate green.



Any combination of outputs may be turned on simultaneously. For example, you could have one, two, or all three<sup>1</sup> monitor outputs turned on at the same time. This way, a pair of full-range speakers could be connected to the monitor A and B

jacks and a subwoofer to the monitor C jacks. The monitor C button could then be used as a “subwoofer in / out” button to compare the sound with and without the subwoofer. More importantly, your friends will call you a genius... and that’s what really counts, right?!

### 35. Trim Knobs

The trim knobs adjust the sensitivity of the monitor output signals. They may be adjusted to any setting between -12 dB and 0 dB [unity at 0 dB] to precisely match the levels among the monitor outputs.

The Big Knob Studio has two trim knobs while the Big Knob Studio<sup>+</sup> possesses an additional trim knob.

### 36. Talkback Level Knob

This knob controls the talkback level. The gain is off when fully counter-clockwise ( $-\infty$ ) and is at maximum gain when fully clockwise (max).

### 37. To 2-Track Button [Big Knob Studio<sup>+</sup>]

When this momentary button is engaged and held, talkback is routed to the 2-track outputs and USB when the Rec Src Select switch is disengaged. Additionally, when engaged the button will illuminate white.

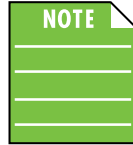

The To 2-Track and To Cue buttons may be engaged simultaneously. The footswitch, however, overrides both buttons.

### 38. To Cue Button

When this momentary button is engaged and held, talkback is routed to the studio outputs and phones outputs.

Additionally, when engaged, the signal is dimmed by 20 dB and the button will illuminate white.



The To 2-Track and To Cue buttons may be engaged simultaneously. The footswitch, however, overrides both buttons.

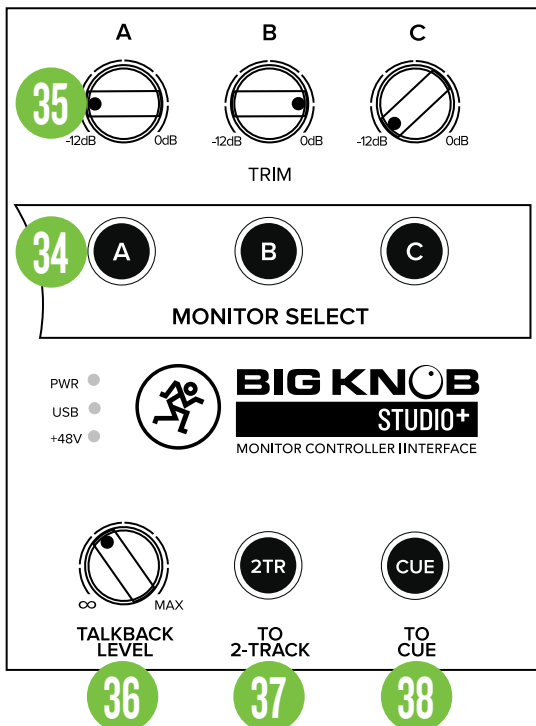

<sup>1</sup> The Big Knob Studio has two monitor select buttons, while the Big Knob Studio<sup>+</sup> possesses an additional monitor select button.

## Appendix A: Service Information

If you think your Big Knob has a problem, please check out the following troubleshooting tips and do your best to confirm the problem. Visit the Support section of our website ([www.mackie.com/support](http://www.mackie.com/support)) where you will find lots of useful information such as FAQs and documentation. You may find the answer to the problem without having to send your Big Knob away.

### Troubleshooting

#### No Power

- **Our favorite question. Is it plugged in?** Make sure that the female end of the line cord is securely seated in the IEC socket of The Power Block and the male end plugged all the way into a live grounded AC outlet. Make sure the locking barrel connector at the end of the cord attached to The Power Block is attached to the power connector of the Big Knob and securely tightened. An LED on The Power Block will illuminate green to indicate success (whether Big Knob is powered on or not).
- **Our second favorite question. Is the rear panel power switch in the ON position?**
- **Make sure the AC outlet is live** (check with a tester or lamp).
- **Is the power LED on the top panel illuminated?**  
If not, make sure the AC outlet is live. If so, refer to “No Sound” below.
- **Are all the lights out in your building?**  
If so, contact your local power company to get power restored.
- **If the power LED is not illuminated, and you are certain that the AC outlet is live, it will be necessary to have the Big Knob serviced.** There are no user serviceable parts inside. Refer to “Repair” at the end of this section to find out how to proceed.

#### No Sound

- **Is the power LED on the top panel illuminated?**  
If not, refer to “No Power” above.
- **Are the correct input source select button(s) selected?**  
Make sure the input source select button is lit.
- **Is the signal source turned up?** Make sure the signal level from the selected input source is high enough to light up some of the input meter LEDs on Big Knob’s top panel.
- **Make sure the trim control and level switch for the selected input(s) are set correctly.**
- **If there is no sound in the phones or studio outputs:**
  - Make sure the studio outs on/off button is on.
  - Make sure the phones and studio level controls are turned up.
- **If there is no sound in the monitor outputs:**
  - Make sure the correct monitor select button(s) are engaged and the trim control for the monitor output(s) are set correctly.
  - Make sure the cable connecting the monitor output to the active speaker or power amplifier isn’t defective and the amplifier/speaker combination is working correctly.

#### Bad Sound

- **Are the input and output connectors plugged completely into the jacks?** Make sure they are plugged all the way in.
- **Is it loud and distorted?** Make sure the trim control and level switch for the selected input is set correctly. Reduce the signal level on the input source if possible.
- **If possible, listen to the signal with headphones plugged into the input source device.** If it sounds bad there, it’s not Big Knob causing the problem.
- **Make sure the trim control for the monitor output is set correctly and not overdriving the input stage of the active speaker or amplifier to which it is connected.**

#### Noise/Hum/Buzz

- **Check the signal cables between the source(s) and the Big Knob.** Make sure all connections are secure. These problems usually produce crackling noises, hum, or buzz. Disconnect them one by one. When the noise goes away, you’ll know which input source is causing the problem.
- **Make sure the signal cable is not routed near AC cables, power transformers, or other EMI sources (including wall warts and line lumps!).** These sources usually produce hum.
- **Excessive hiss is an indication of an incorrect gain setting somewhere before the Big Knob.**
- **Sometimes it helps to plug all the audio equipment into the same AC circuit so they share a common ground.**

### Repair

For warranty service, please refer to the warranty information on page 24.

Non-warranty service is available at a factory-authorized service center. To locate the nearest service center, visit [www.mackie.com](http://www.mackie.com), click “Support” and select “Locate a Service Center or Distributor”. Service for a Big Knob Passive living outside the United States may be obtained through local dealers or distributors.

If you do not have access to our website, please call our Tech Support department at 1-800-898-3211 (normal business hours, Pacific Time), to explain the problem. They will tell you where the nearest factory-authorized service center is located in your area.

# Appendix B: Technical Information

## Big Knob Specifications

### Frequency Response

Unity gain, +4 dBu input	
All inputs:	±0.5 dB, 20 Hz – 20 kHz
All outputs:	±0.5 dB, 20 Hz – 20 kHz

### Noise Characteristics

150 ohm terminated, 22 kHz bandwidth	
Mic inputs to outputs (EIN):	< -125 dBu RMS, A-weighted
Line inputs to outputs:	< -90 dBu RMS, un-weighted

### Distortion (THD+N)

Unity gain, 1 kHz @ +4 dBu input, 80 kHz bandwidth	
All inputs to outputs:	< 0.01%, un-weighted

### Crosstalk (between left and right channels)

Unity gain, -1 dBFS input	
Mic inputs to outputs:	< -60 dB at 1 kHz
Line inputs to outputs:	< -60 dB at 1 kHz

### Attenuation

Muted:	-60 dB
Dim:	-20 dB

### Maximum Levels (before clipping)

All inputs:	+22 dBu
All outputs:	+22 dBu

### Input Type

Input type:	Female XLR balanced/ unbalanced
	Female 1/4" balanced / unbalanced
	Female 1/8" unbalanced

### Output Type

Output type:	Female 1/4" balanced / unbalanced
--------------	-----------------------------------

### USB

Format:	USB 2.0, 24-bit, 192 kHz
---------	--------------------------

### Power Requirements

Universal Power Supply:	100 – 240 V- 50/60 Hz 0.75A
-------------------------	-----------------------------

### Physical Dimensions and Weight

#### Big Knob Studio

Height:	3.2 in / 81 mm
Width:	9.9 in / 251 mm
Depth:	6.4 in / 163 mm
Weight:	3.5 lb / 1.6 kg

#### Big Knob Studio+

Height:	3.2 in / 81 mm
Width:	11.9 in / 302 mm
Depth:	6.8 in / 173 mm
Weight:	4.6 lb / 2.1 kg

### Disclaimer

LOUD Audio, LLC. is always striving to improve our products by incorporating new and improved materials, components and manufacturing methods. Therefore, we reserve the right to change these specifications at any time without notice.

## Big Knob Studio Dimensions

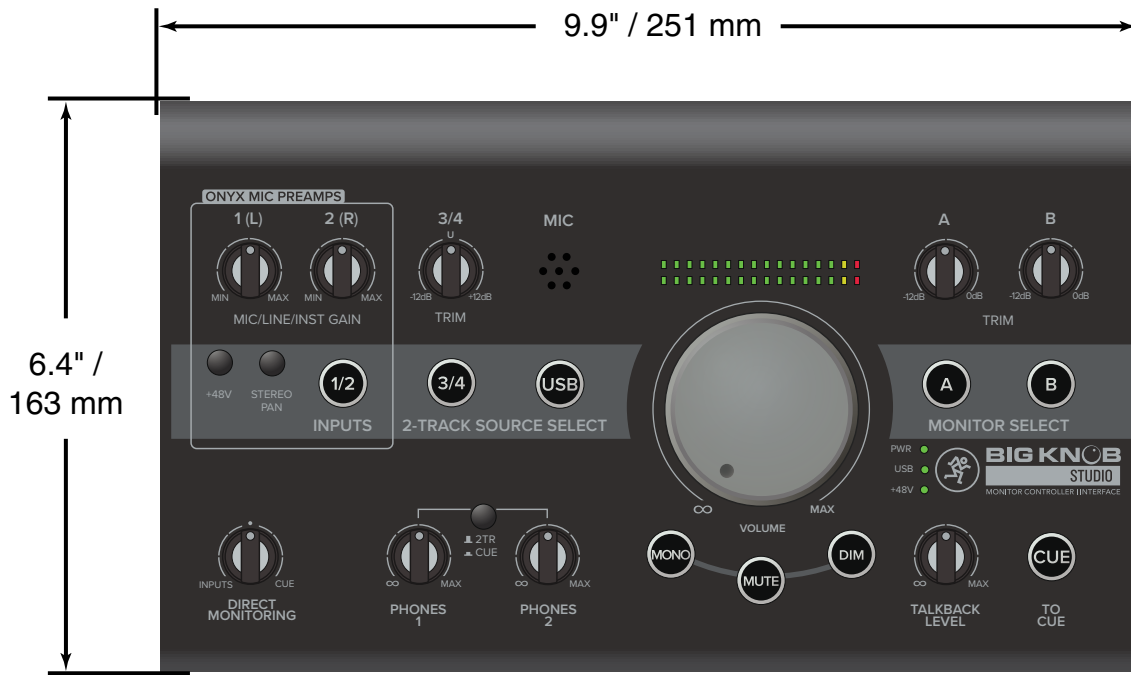

# Big Knob Studio+ Dimensions

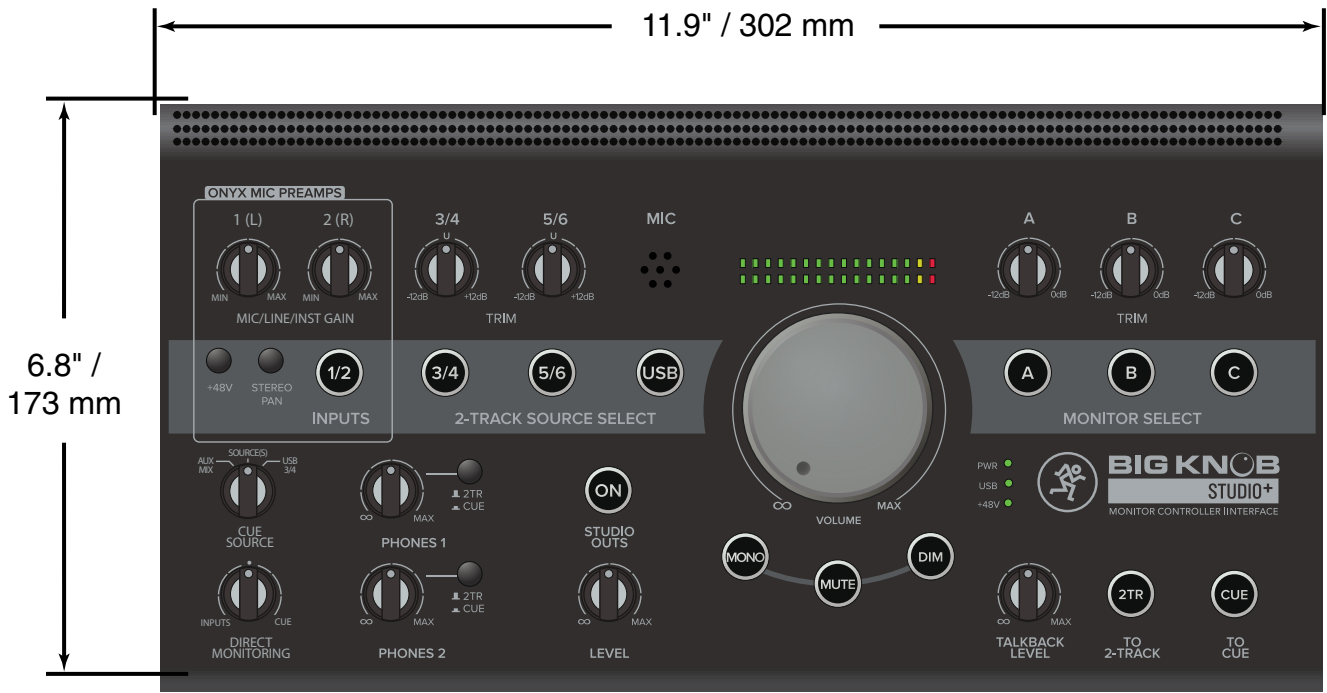

WEIGHT  
4.6 lb /  
2.1 kg



## Big Knob Studio Block Diagram

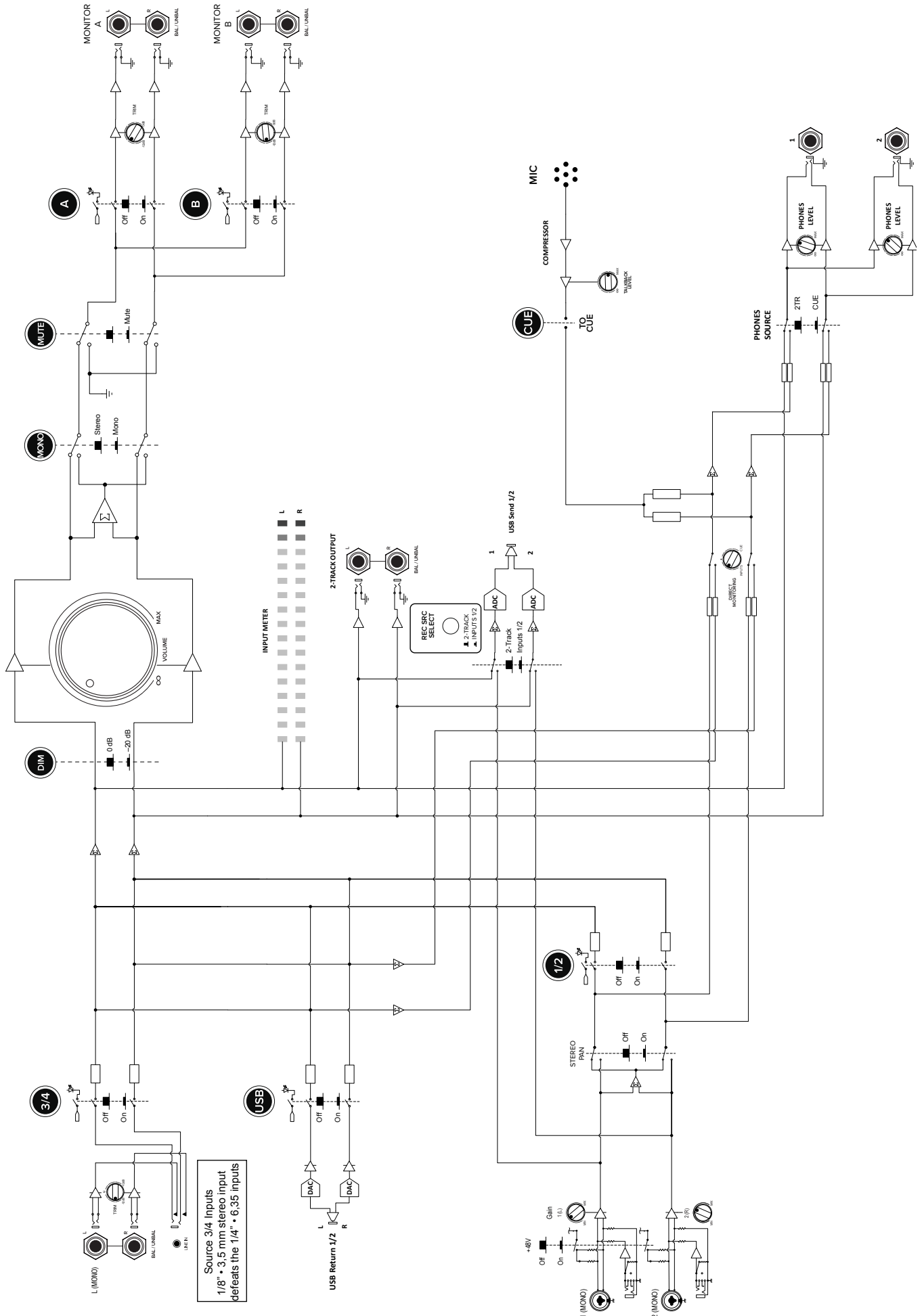

# Big Knob Studio+ Block Diagram

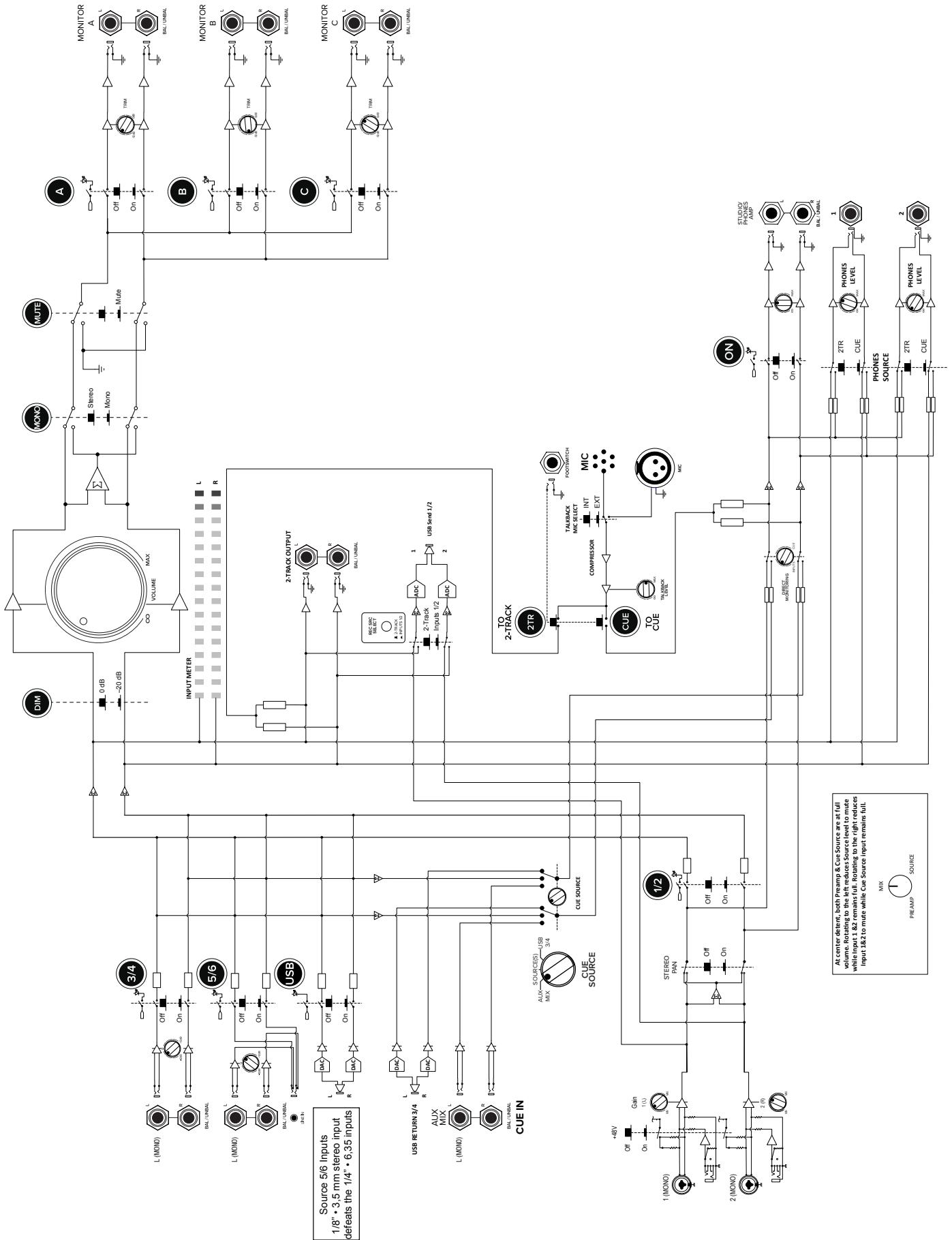

## Limited Warranty

### Please keep your sales receipt in a safe place.

This Limited Product Warranty (“Product Warranty”) is provided by LOUD Audio, LLC. (“LOUD”) and is applicable to products purchased in the United States or Canada through a LOUD-authorized reseller or dealer. The Product Warranty will not extend to anyone other than the original purchaser of the product (hereinafter, “Customer,” “you” or “your”).

For products purchased outside the U.S. or Canada, please visit [www.mackie.com](http://www.mackie.com) to find contact information for your local distributor, and information on any warranty coverage provided by the distributor in your local market.

LOUD warrants to Customer that the product will be free from defects in materials and workmanship under normal use during the Warranty Period. If the product fails to conform to the warranty then LOUD or its authorized service representative will at its option, either repair or replace any such nonconforming product, provided that Customer gives notice of the noncompliance within the Warranty Period to the Company at: [www.mackie.com](http://www.mackie.com) or by calling LOUD technical support at 1.800.898.3211 (toll-free in the U.S. and Canada) during normal business hours Pacific Time, excluding weekends or LOUD holidays. Please retain the original dated sales receipt as evidence of the date of purchase. You will need it to obtain any warranty service.

For full terms and conditions, as well as the specific duration of the Warranty for this product, please visit [www.mackie.com](http://www.mackie.com).

The Product Warranty, together with your invoice or receipt, and the terms and conditions located at [www.mackie.com](http://www.mackie.com) constitutes the entire agreement, and supersedes any and all prior agreements between LOUD and Customer related to the subject matter hereof. No amendment, modification or waiver of any of the provisions of this Product Warranty will be valid unless set forth in a written instrument signed by the party to be bound thereby.

### Need help with the Big Knob?

- Visit [www.mackie.com](http://www.mackie.com) and click Support to find: FAQs, manuals, and addendums.
- Telephone 1-800-898-3211 to speak with one of our splendid technical support chaps (Monday through Friday, normal business hours, Pacific Time).





---

**19820 North Creek Parkway #201  
Bothell, WA 98011 • USA  
Phone: 425.487.4333  
Toll-free: 800.898.3211  
Fax: 425.487.4337  
[www.mackie.com](http://www.mackie.com)**

---