

HOOKUP DIAGRAMS

Quick Start

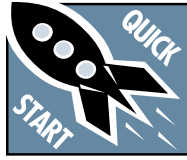

Make all initial connections with the power switches OFF on all equipment. Make sure all master volume, level, or gain controls are all the way down.

1. Connect the line-level outputs from your mixing console (or other signal source) to the inputs of your power amplifier.
2. Connect the “Speaker Output” from your power amplifier (or powered mixer) to the INPUT connector on the C200.
3. Turn on your mixing console (or other signal source).
4. Turn on the amplifier. Turn up its volume or gain control(s) as recommended by the manufacturer.
5. Start the signal source, whether it be speaking into a microphone or starting a CD player. Adjust the volume controls on the mixer (or other signal source) for normal operation.

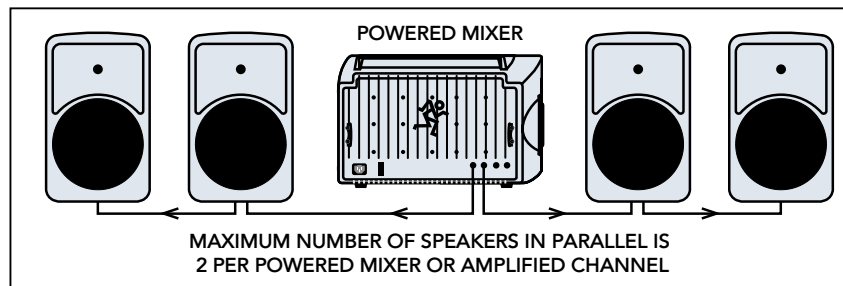

C200: WITH A MACKIE POWERED MIXER, AND USING THE THRU JACK

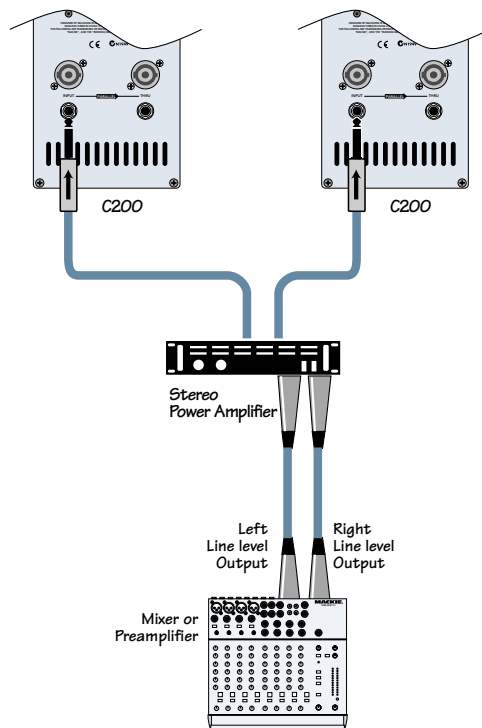

C200: WITH A MIXER AND POWER AMPLIFIER

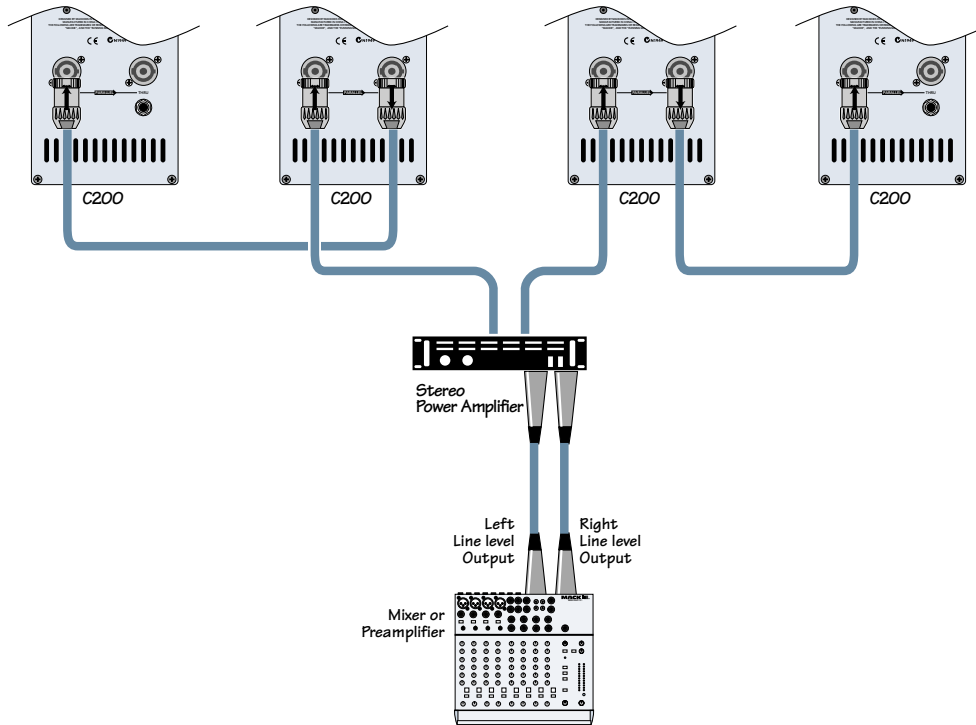

C200: WITH A MIXER AND POWER AMPLIFIER, AND USING THE THRU JACK

The C200 can be used with a Mackie SWA1501 (or SWA1801) subwoofer to create an incredibly powerful system.

The active crossover inside the subwoofer splits the full-range stereo input signal into two ranges. The SWA1501 sums the left and right low-frequency range and plays it through its built-in amplifier and 15-inch woofer. It sends the stereo high-pass range to the C200s, via an external power amplifier.

The C200 can be pole mounted on top of the SWA1501 or 1801 as shown.

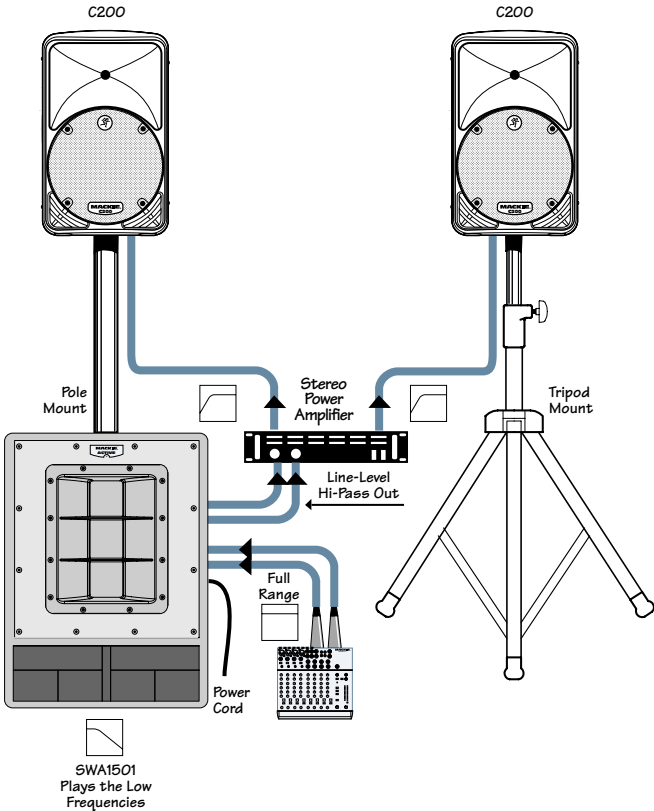

C200: BIAMPING WITH A POWERED SUBWOOFER